

# VXI/VME

---

## VXI/VMEpc™ 600 Series User Manual

**Internet Support**

E-mail: [support@natinst.com](mailto:support@natinst.com)

FTP Site: <ftp.natinst.com>

Web Address: <http://www.natinst.com>

**Bulletin Board Support**

BBS United States: 512 794 5422

BBS United Kingdom: 01635 551422

BBS France: 01 48 65 15 59

**Fax-on-Demand Support**

512 418 1111

**Telephone Support (USA)**

Tel: 512 795 8248

Fax: 512 794 5678

**International Offices**

Australia 03 9879 5166, Austria 0662 45 79 90 0, Belgium 02 757 00 20, Brazil 011 288 3336,  
Canada (Ontario) 905 785 0085, Canada (Québec) 514 694 8521, Denmark 45 76 26 00, Finland 09 725 725 11,  
France 01 48 14 24 24, Germany 089 741 31 30, Hong Kong 2645 3186, Israel 03 6120092, Italy 02 413091,  
Japan 03 5472 2970, Korea 02 596 7456, Mexico 5 520 2635, Netherlands 0348 433466, Norway 32 84 84 00,  
Singapore 2265886, Spain 91 640 0085, Sweden 08 730 49 70, Switzerland 056 200 51 51, Taiwan 02 377 1200,  
United Kingdom 01635 523545

**National Instruments Corporate Headquarters**

6504 Bridge Point Parkway Austin, Texas 78730-5039 USA Tel: 512 794 0100

# Important Information

---

## Warranty

The National Instruments VXI/VMEpc 600 Series embedded computers and accessories are warranted against defects in materials and workmanship for a period of one year from the date of shipment, as evidenced by receipts or other documentation. National Instruments will, at its option, repair or replace equipment that proves to be defective during the warranty period. This warranty includes parts and labor.

The media on which you receive National Instruments software are warranted not to fail to execute programming instructions, due to defects in materials and workmanship, for a period of 90 days from date of shipment, as evidenced by receipts or other documentation. National Instruments will, at its option, repair or replace software media that do not execute programming instructions if National Instruments receives notice of such defects during the warranty period. National Instruments does not warrant that the operation of the software shall be uninterrupted or error free.

A Return Material Authorization (RMA) number must be obtained from the factory and clearly marked on the outside of the package before any equipment will be accepted for warranty work. National Instruments will pay the shipping costs of returning to the owner parts which are covered by warranty.

National Instruments believes that the information in this manual is accurate. The document has been carefully reviewed for technical accuracy. In the event that technical or typographical errors exist, National Instruments reserves the right to make changes to subsequent editions of this document without prior notice to holders of this edition. The reader should consult National Instruments if errors are suspected. In no event shall National Instruments be liable for any damages arising out of or related to this document or the information contained in it.

EXCEPT AS SPECIFIED HEREIN, NATIONAL INSTRUMENTS MAKES NO WARRANTIES, EXPRESS OR IMPLIED, AND SPECIFICALLY DISCLAIMS ANY WARRANTY OF MERCHANTABILITY OR FITNESS FOR A PARTICULAR PURPOSE. CUSTOMER'S RIGHT TO RECOVER DAMAGES CAUSED BY FAULT OR NEGLIGENCE ON THE PART OF NATIONAL INSTRUMENTS SHALL BE LIMITED TO THE AMOUNT THEREFORE PAID BY THE CUSTOMER. NATIONAL INSTRUMENTS WILL NOT BE LIABLE FOR DAMAGES RESULTING FROM LOSS OF DATA, PROFITS, USE OF PRODUCTS, OR INCIDENTAL OR CONSEQUENTIAL DAMAGES, EVEN IF ADVISED OF THE POSSIBILITY THEREOF. This limitation of the liability of National Instruments will apply regardless of the form of action, whether in contract or tort, including negligence. Any action against National Instruments must be brought within one year after the cause of action accrues. National Instruments shall not be liable for any delay in performance due to causes beyond its reasonable control. The warranty provided herein does not cover damages, defects, malfunctions, or service failures caused by owner's failure to follow the National Instruments installation, operation, or maintenance instructions; owner's modification of the product; owner's abuse, misuse, or negligent acts; and power failure or surges, fire, flood, accident, actions of third parties, or other events outside reasonable control.

## Copyright

Under the copyright laws, this publication may not be reproduced or transmitted in any form, electronic or mechanical, including photocopying, recording, storing in an information retrieval system, or translating, in whole or in part, without the prior written consent of National Instruments Corporation.

## Trademarks

CVI™, LabVIEW™, MANTIS™, MITE™, NI-488.2™, NI-VISA™, NI-VXI™, TNT4882C™, and VXI/VMEpc™ are trademarks of National Instruments Corporation.

Product and company names listed are trademarks or trade names of their respective companies.

## WARNING REGARDING MEDICAL AND CLINICAL USE OF NATIONAL INSTRUMENTS PRODUCTS

National Instruments products are not designed with components and testing intended to ensure a level of reliability suitable for use in treatment and diagnosis of humans. Applications of National Instruments products involving medical or clinical treatment can create a potential for accidental injury caused by product failure, or by errors on the part of the user or application designer. Any use or application of National Instruments products for or involving medical or clinical treatment must be performed by properly trained and qualified medical personnel, and all traditional medical safeguards, equipment, and procedures that are appropriate in the particular situation to prevent serious injury or death should always continue to be used when National Instruments products are being used. National Instruments products are NOT intended to be a substitute for any form of established process, procedure, or equipment used to monitor or safeguard human health and safety in medical or clinical treatment.

# Compliance

---

## FCC/DOC Radio Frequency Interference Class A Compliance

This equipment generates and uses radio frequency energy and, if not installed and used in strict accordance with the instructions in this manual, may cause interference to radio and television reception. Classification requirements are the same for the Federal Communications Commission (FCC) and the Canadian Department of Communications (DOC). This equipment has been tested and found to comply with the following two regulatory agencies:

### Federal Communications Commission

This equipment has been tested and found to comply with the limits for a Class A digital device, pursuant to part 15 of the FCC Rules. These limits are designed to provide reasonable protection against harmful interference when the equipment is operated in a commercial environment. This equipment generates, uses, and can radiate radio frequency energy and, if not installed and used in accordance with the instruction manual, may cause harmful interference to radio communications. Operation of this equipment in a residential area is likely to cause harmful interference in which case the user will be required to correct the interference at his own expense.

**Notices to User:** *Changes or modifications not expressly approved by National Instruments could void the user's authority to operate the equipment under the FCC Rules.*

*This device complies with the FCC rules only if used with shielded interface cables of suitable quality and construction. National Instruments used such cables to test this device and provides them for sale to the user. The use of inferior or nonshielded interface cables could void the user's authority to operate the equipment under the FCC rules.*

If necessary, consult National Instruments or an experienced radio/television technician for additional suggestions. The following booklet prepared by the FCC may also be helpful: *Interference to Home Electronic Entertainment Equipment Handbook*. This booklet is available from the U.S. Government Printing Office, Washington, DC 20402.

### Canadian Department of Communications

This Class A digital apparatus meets all requirements of the Canadian Interference-Causing Equipment Regulations.

Cet appareil numérique de la classe A respecte toutes les exigences du Règlement sur le matériel brouilleur du Canada.

# Contents

---

## About This Manual

Organization of This Manual .....	ix
Conventions Used in This Manual.....	x
How to Use This Documentation Set .....	xi
Related Documentation.....	xii
Customer Communication .....	xii

## Chapter 1

### Introduction

Overview.....	1-1
Optional Equipment.....	1-3
National Instruments Software .....	1-3
Hardware Description .....	1-4
VXI Slot 0 Functionality .....	1-4
VME Slot 1 Functionality .....	1-4
Custom Application-Specific Interface Chips.....	1-4
Front Panel Features .....	1-5

## Chapter 2

### Functional Overview

VXI/VMEpc 600 Series Functional Description .....	2-1
---	-----

## Chapter 3

### Configuration and Installation

Default Settings.....	3-1
Configuring the VXI/VMEpc 600 Series .....	3-6
VXI/VMEbus System Controller/Non-System Controller.....	3-6
VXIbus CLK10 Routing (VXIpc 600 Series Only) .....	3-7
Trigger Input Termination (VXIpc 600 Series Only).....	3-9
MITE EEPROM .....	3-10
How to Fix an Invalid EEPROM Configuration.....	3-11
Configuring the PC .....	3-12
SCSI Termination.....	3-12
System CMOS .....	3-12
Installing the VXI/VMEpc 600 Series .....	3-13

## **Chapter 4 BIOS**

Entering BIOS Setup .....	4-1
Default BIOS Setup Settings .....	4-1

## **Appendix A Specifications**

## **Appendix B LED Indicators**

## **Appendix C Front Panel and Connectors**

## **Appendix D Common Questions**

## **Appendix E Customer Communication**

## **Glossary**

## **Index**

## **Figures**

Figure 1-1. VXIpc-650 Embedded Controller .....	1-1
Figure 1-2. VMEpc-650 Embedded Controller .....	1-2
Figure 2-1. VXI/VMEpc 600 Series Block Diagram .....	2-2
Figure 3-1. VXIpc-650 Parts Locator Diagram .....	3-2
Figure 3-2. VMEpc-650 Parts Locator Diagram .....	3-3
Figure 3-3. CPU Module Attached to VXI/VMEpc-650 .....	3-4
Figure 3-4. System Controller Slot Configuration .....	3-6
Figure 3-5. VXIbus CLK10 Routing .....	3-7
Figure 3-6. SMB CLK10 Direction .....	3-8
Figure 3-7. SMB CLK10 Termination .....	3-8

Figure 3-8.	SMB CLK10 Polarity .....	3-9
Figure 3-9.	SMB Trigger Input Termination .....	3-9
Figure 3-10.	Power-on Self Configuration Status .....	3-10
Figure 3-11.	EEPROM Configuration .....	3-11
Figure 3-12.	SCSI Termination .....	3-12
Figure 3-13.	System CMOS .....	3-13
Figure C-1.	VXIpc-650 Front Panel Layout and Dimensions .....	C-2
Figure C-2.	VMEpc-650 Front Panel Layout and Dimensions .....	C-3
Figure C-3.	Keyboard and Mouse Connectors Location and Pinout .....	C-4
Figure C-4.	VGA Connector Location and Pinout .....	C-5
Figure C-5.	Ethernet Connector Location and Pinout .....	C-6
Figure C-6.	COM1 and COM2 Connectors Location and Pinout .....	C-8
Figure C-7.	Parallel Port Connector Location and Pinout .....	C-9
Figure C-8.	USB Connectors Location and Pinout .....	C-11
Figure C-9.	SCSI Connector Location and Pinout .....	C-12
Figure C-10.	GPIB Connector Location and Pinout .....	C-14
Figure C-11.	SMB Connectors Location and Pinout .....	C-16
Figure C-12.	VXIbus Connectors Location and Pinout .....	C-18

## Tables

Table 1-1.	VXI/VMEpc 600 Series Peripherals Overview .....	1-6
Table 3-1.	VXI/VMEpc 600 Series Hardware Default Settings .....	3-5
Table B-1.	LEDs and System Startup Status .....	B-2
Table C-1.	Keyboard and Mouse Connector Signals .....	C-4
Table C-2.	VGA Connector Signals .....	C-5
Table C-3.	Ethernet Connector Signals .....	C-7
Table C-4.	COM1 and COM2 Connector Signals .....	C-8
Table C-5.	Parallel Port Connector Signals .....	C-10
Table C-6.	USB Connector Signals .....	C-11
Table C-7.	16-Bit Wide SCSI-3 “P” (Primary) Connector Pinout (Single Ended) .....	C-12
Table C-8.	GPIB Connector Signals .....	C-15
Table C-9.	SMB Connector Signals .....	C-16
Table C-10.	Signal Characteristics for SMB Connections .....	C-17
Table C-11.	VXI/VMEbus P1 Connector Signals .....	C-19
Table C-12.	VXIbus P2 Connector Signals .....	C-20
Table C-13.	VMEbus P2 Connector Signals .....	C-21

# About This Manual

---

This manual contains instructions for installing and configuring the National Instruments VXI/VMEpc 600 Series embedded computer kit. The VXI/VMEpc 600 Series includes all the models of the VXIpc 600 Series and VMEpc 600 Series embedded computers.

## Organization of This Manual

---

This manual is organized as follows:



- Chapter 1, *Introduction*, describes the VXI/VMEpc 600 Series of embedded VXI computers, lists what you need to get started, describes the hardware, and lists optional equipment and software.
- Chapter 2, *Functional Overview*, contains functional descriptions of each major logic block on the VXI/VMEpc 600 Series.
- Chapter 3, *Configuration and Installation*, contains the instructions to configure and install the VXI/VMEpc 600 Series.
- Chapter 4, *BIOS*, contains information on BIOS (Basic Input Output System), the low-level interface between the hardware and PC software that configures and tests your hardware at boot up.
- Appendix A, *Specifications*, describes the environmental, electrical, and mechanical specifications of the VXI/VMEpc 600 Series.
- Appendix B, *LED Indicators*, describes how to read the LEDs on the front panel to interpret the status of the VXI/VMEpc 600 Series.
- Appendix C, *Front Panel and Connectors*, describes the front panel and connectors on the VXI/VMEpc 600 Series.
- Appendix D, *Common Questions*, answers common questions you may have when using the VXI/VMEpc 600 Series.
- Appendix E, *Customer Communication*, contains forms you can use to request help from National Instruments or to comment on our products and manuals.
- The *Glossary* contains an alphabetical list and description of terms used in this manual, including abbreviations, acronyms, metric prefixes, mnemonics, and symbols.
- The *Index* contains an alphabetical list of key terms and topics used in this manual, including the page where you can find each one.



# Conventions Used in This Manual

---

The following conventions are used in this manual:

<>	Angle brackets enclose the name of a key on the keyboard—for example, <Enter>.
-	A hyphen between two or more key names enclosed in angle brackets denotes that you should simultaneously press the named keys—for example, <Control-Alt-Delete>.
◆	The ◆ symbol indicates that the text following it applies only to a specific product, a specific operating system, or a specific software version.
	This icon to the left of bold italicized text denotes a note, which alerts you to important information.
	This icon to the left of bold italicized text denotes a caution, which advises you of precautions to take to avoid injury, data loss, or a system crash.
	This icon to the left of bold italicized text denotes a warning, which advises you of precautions to take to avoid being electrically shocked.
<b>bold</b>	Bold text denotes the names of menus, menu items, dialog box buttons or options, or LEDs.
<b><i>bold italic</i></b>	Bold italic text denotes a note, caution, or warning.
<i>italic</i>	Italic text denotes variables, emphasis, a cross reference, or an introduction to a key concept.
monospace	Text in this font denotes text or characters that you should literally enter from the keyboard, sections of code, programming examples, and syntax examples. This font is also used for the proper names of disk drives, paths, directories, programs, subprograms, subroutines, device names, functions, variables, filenames, and extensions.
<b>monospace bold</b>	Bold text in this font denotes the messages and responses that the computer automatically prints to the screen.
VXI/VMEpc 600 Series	The term <i>VXI/VMEpc 600 Series</i> refers to a series of B-size, two-slot VXI or VME embedded controllers. Currently, this series consists of the VXIpc-650 and VMEpc-650. This term is used when information applies equally to either the VXI or VME model.

# How to Use This Documentation Set

---

Begin by reading the *Getting Started with Your VXI/VMEpc 600 Series* manual for your operating system to get basic instructions for setting up the hardware and software. This brief quick-start manual describes how to get started with your kit using the default hardware and software settings, and how to configure and use the NI-VXI software. Refer to the following manuals for more information about the hardware or software.

This manual, the *VXI/VMEpc 600 Series User Manual*, contains more details about changing the installation or configuration from the defaults, and using the hardware.

When you are familiar with the material in these manuals, you can begin to use the *NI-VXI User Manual*. This manual presents the concepts of VXI and prepares you for detailed explanations of the NI-VXI functions. The NI-VXI online help describes the NI-VXI functions to help you fully understand the purpose and syntax of each function. You can find this same information in the *NI-VXI Programmer Reference Manual*. These two manuals are available in the `c:\NIVXI\Manuals` directory under the names `NI-VXIUsersMan.pdf` and `NI-VXIProgrammerMan.pdf`, respectively. Use the Acrobat Reader program, Version 3 or later, to open these files.

You can also access the NI-VXI online help for Windows 95/NT in the `NIVXI` folder.

Refer to the *NI-VXI Graphical Utilities Reference Manual* and the *NI-VXI Text Utilities Reference Manual* to learn more about the NI-VXI utilities.

Refer to the *NI-VISA User Manual* to learn about VISA and how to use it in your system. The NI-VISA online help describes the attributes, events, and operations you can use in NI-VISA. You can find this same information in the *NI-VISA Programmer Reference Manual*. These two manuals are available in the `c:\Vxipnp\os\NIvvisa\Manuals` directory (where `os` is either `Win95` or `WinNT`) under the names `NI-VISAUsersMan.pdf` and `NI-VISAProgrammersMan.pdf`, respectively. Use the Acrobat Reader program, Version 3 or later, to open these files.

## Related Documentation

---

The following documents contain information that you may find helpful as you read this manual:

- ANSI/IEEE Standard 1014-1987, *IEEE Standard for a Versatile Backplane Bus: VMEbus*
- ANSI/IEEE Standard 1155-1993, *IEEE VMEbus Extensions for Instrumentation: VXIbus*
- ANSI/VITA 1-1994, *VME64*
- VXI-6, *VXIbus Mainframe Extender Specification*, Rev. 1.0, VXIbus Consortium

## Customer Communication

---

National Instruments wants to receive your comments on our products and manuals. We are interested in the applications you develop with our products, and we want to help if you have problems with them. To make it easy for you to contact us, this manual contains comment and configuration forms for you to complete. These forms are in Appendix E, [Customer Communication](#), at the end of this manual.

---

# Introduction

This chapter describes the VXI/VMEpc 600 Series of embedded VXI computers, lists what you need to get started, describes the hardware, and lists optional equipment and software.

---

## Overview

The VXI/VMEpc 600 Series consists of the VXIpc-650 and VMEpc-650 models, which are functionally equivalent in many ways. Figure 1-1 shows the VXI model and Figure 1-2 shows the VME model. Refer to Appendix C, *Front Panel and Connectors*, for information about the location and pinout assignment of each connector on the module.

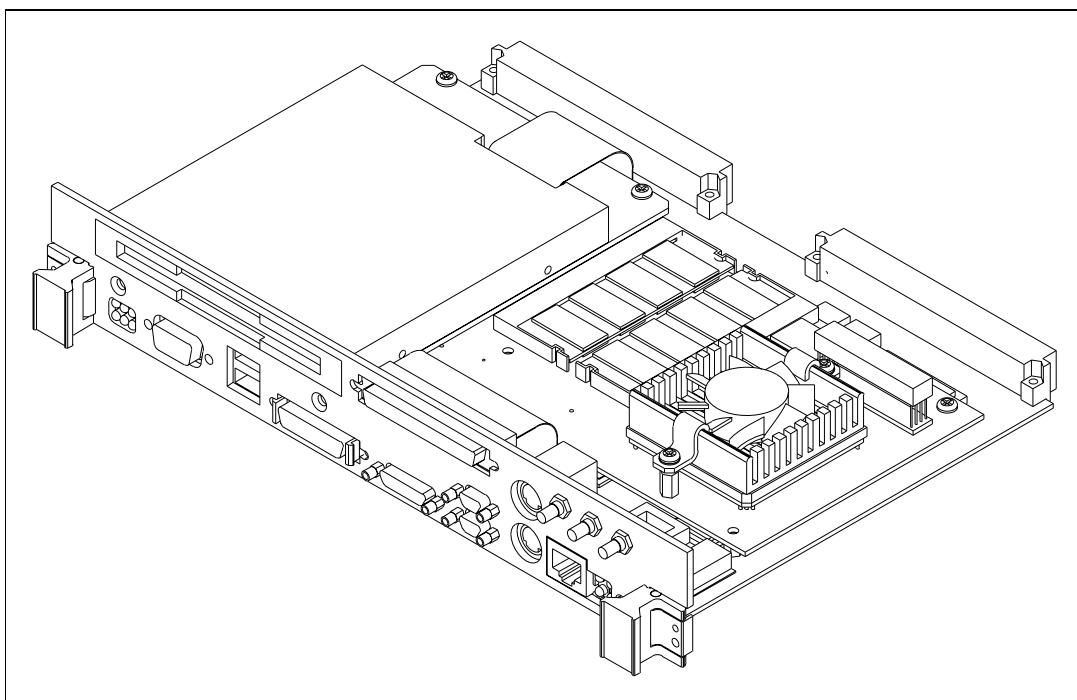

**Figure 1-1.** VXIpc-650 Embedded Controller

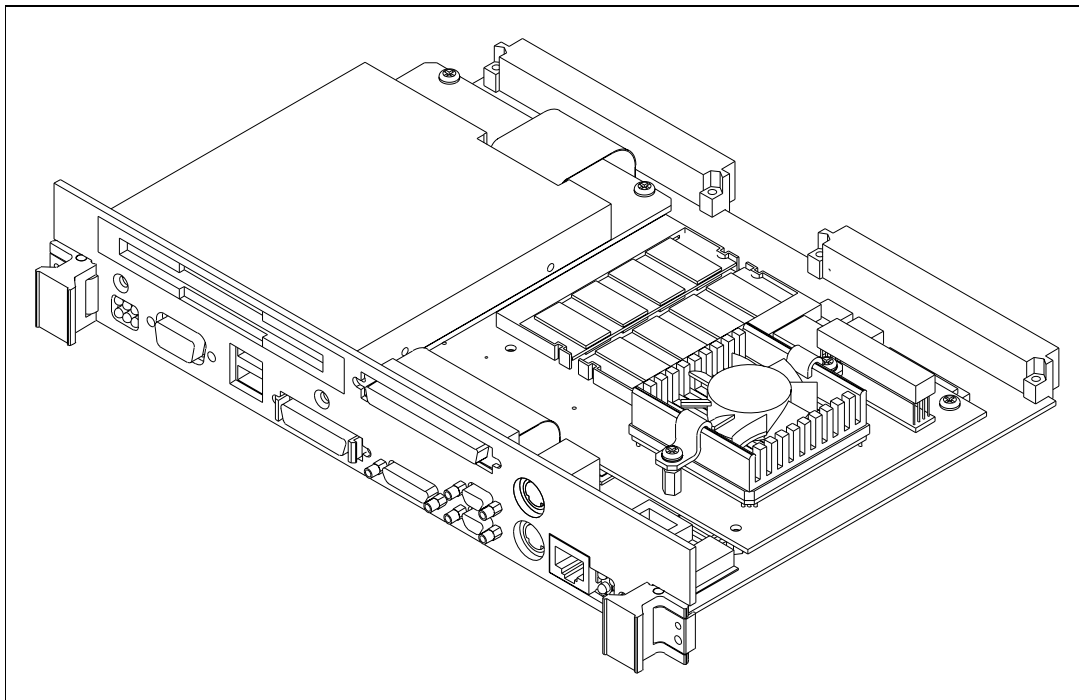

**Figure 1-2.** VMEpc-650 Embedded Controller

The VXI/VMEpc 600 Series controllers are B-size, embedded computers based on x86 Processor architecture and on the Peripheral Component Interface (PCI) bus. These computers are high-performance, easy-to-use platforms for controlling VXI/VMEbus systems, featuring complete VXI and VME functionality through interactive utilities and C function calls. In addition, the VXI/VMEpc 600 Series has Ethernet capability plus an IEEE 488.2 interface that is compatible with the NI-488.2 architecture.

The VXI/VMEpc 600 Series is a custom computer that you install directly in two B-size slots of your VXI or VME mainframe. An embedded computer can take full advantage of the VXI/VME high-performance backplane capabilities and give you direct control of VXI registers, memory, interrupts, and triggers.

All models in the VXI/VMEpc 600 Series are fully VXI *plug&play* compliant and are compatible with PC-compatible software tools, the National Instruments LabVIEW and LabWindows/CVI application software, and the NI-VXI, NI-VISA, and NI-488.2 bus interface software.

## Optional Equipment

---

You can contact National Instruments to order any of the following optional equipment:

- COM1/2 adapter cable
- Enhanced parallel port adapter cable
- Single-shielded 2 m GPIB cable

## National Instruments Software

---

National Instruments has developed several software kits you can use with the VXI/VMEpc 600 Series. The NI-VXI bus interface software includes a Resource Manager, an interactive VXI resource editor program, a comprehensive library of software routines for VXI/VME programming, and an interactive control program for interacting with VXI/VME. You can use this software to seamlessly program multiple-mainframe configurations and have software compatibility across a variety of VXI/VME controller platforms.

The NI-488.2M software kit gives you access to the industry-standard NI-488.2M software for controlling external GPIB instruments through the GPIB port on the front panel of your VXI/VMEpc 600 Series. The GPIB interface on your VXI/VMEpc controller is fully compatible with the NI-488.2M driver for a variety of operating systems. Any software using NI-488.2M will run on the VXI/VMEpc 600 Series.

You can use the NI-VISA high-level programming API to program GPIB, serial, parallel, and VXI/VME devices in much the same manner.

You can also use the National Instruments LabVIEW and LabWindows/CVI application programs and instrument drivers to ease your programming task. These standardized programs match the modular virtual instrument capability of VXI and can reduce your VXI/VMEbus software development time. These programs are fully *VXIplug&play* compliant and feature extensive libraries of GPIB, Serial, and VXI instrument drivers written to take full advantage of direct VXI control. LabVIEW and LabWindows/CVI include all the tools needed for instrument control, data acquisition, analysis, and presentation.

LabVIEW is a complete programming environment that departs from the sequential nature of traditional programming languages and features a graphical programming environment.

LabWindows/CVI is an interactive C development environment for building test and measurement and instrument control systems. It includes interactive code-generation tools and a graphical editor for building custom user interfaces.

## Hardware Description

---

### VXI Slot 0 Functionality

You can use the VXIpc 600 Series computers to achieve full VXI Slot 0 control of your VXI system. You can also install the module in another slot and use it in Non-Slot 0 mode. You do not have to change any jumpers when moving between these two modes, as the VXIpc 600 Series automatically detects whether it is installed in Slot 0 and automatically enables or disables the onboard Slot 0 circuitry.

### VME Slot 1 Functionality

In the same way, you can install the VMEpc-650 in Slot 1 for full System Controller functionality, or you can use it in Non-Slot 1 mode. The VMEpc-650 automatically detects whether it is in the System Controller slot and it automatically enables or disables the onboard Slot 1 circuitry.

### Custom Application-Specific Interface Chips

The VXI/VMEpc 600 Series uses the MITE and MANTIS custom ASICs to deliver high VXI/VME performance DMA block-mode data transfer rates across the VXI/VME backplane.

The VXI/VMEpc 600 Series has the TNT4882C custom ASIC to give full GPIB control of external instruments via a front-panel connector. GPIB capability is fully compatible with IEEE 488.2 and the industry-standard NI-488.2 driver for a variety of operating systems.

The MITE custom ASIC is a sophisticated dual-channel DMA controller with standard interfaces for VXI and PCI. By using MITE DMA to transfer data and commands to and from devices, the MITE frees the computer's microprocessor to perform other tasks such as data analysis and presentation. In addition to DMA, the MITE incorporates the new VME64 MBLT—8-byte block transfers in which both the address bus and data bus are used to transfer data—directly into the ASIC to perform the fastest transfer operation to instruments. With the multiple windowing scheme of the MITE, you can easily access all of VXI/VME address space.

- ◆ **VXI users only**—The VXI trigger interface on the VXIpc 600 Series controller is based on the MANTIS custom ASIC. The front panel has two SMB trigger I/O connectors, which you can use to route any of the TTL trigger lines between the backplane and external devices. The MANTIS ASIC on the controller provides the complete VXI interface to the backplane connector in a single chip. The VXIpc 600 Series can respond to all VXI-defined protocols on all P2 TTL and ECL trigger lines at the same time. The MANTIS features an internal cross-matrix switching system for routing between lines as well as to and from the front panel and onboard clocks.

**Note**

*The MANTIS ASIC contains the exact functionality of the TIC ASIC, which appeared on the VXIpc-486 Model 500 Series controllers. Any application that currently uses any of the TIC functionality, such as the crosspoint switch and counter/timers, can run on a controller containing the MANTIS ASIC without modification.*

## Front Panel Features

The VXI/VMEpc 600 Series has the following front-panel features:

- Internal 3.5 in. floppy drive
- System reset push-button
- Up to 14 front-panel connectors as listed below:
  - Two RS-232 Serial
  - Extended Capabilities Parallel (ECP)
  - Super VGA
  - GPIB (IEEE 488.2)
  - 10/100 BaseT Ethernet
  - Ultra Wide SCSI
  - PS/2-Style Keyboard
  - PS/2-Style Mouse
  - Two Universal Serial Bus (USB)
  - External Clock (VXIpc only)
  - Trigger Output (VXIpc only)
  - Trigger Input (VXIpc only)
- Six front-panel LEDs that show VXI and PC status:
  - **SYSF** LED indicates that the VXI/VMEbus SYSFAIL line is asserted.



- **FAIL** LED indicates that the VXI/VMEpc-650 is driving the SYSFAIL signal.
- **TEST** LED indicates that the VXI/VMEpc-650 is performing its self-tests or startup Resource Manager operations.
- **ONLINE** LED indicates that the VXI/VMEpc-650 is performing or has completed its startup Resource Manager operations.
- **ACC** LED indicates when the VXI/VMEpc-650 MODID line is asserted or the VXIbus registers or shared memory are accessed by another bus master.
- **DRV** LED indicates when the internal hard drive is in use.
- Four front-panel LEDs that show Ethernet port status:
  - **RX** LED indicates that the VXI/VMEpc-650 Series is receiving data through its Ethernet port.
  - **TX** LED indicates that the VXI/VMEpc-650 Series is transmitting data through its Ethernet port.
  - **LNK** LED reflects Ethernet link status.
  - **100B-T** LED indicates Fast Ethernet Link at 100 Mbits/s when lit.

**Table 1-1.** VXI/VMEpc 600 Series Peripherals Overview

Peripheral	External Connector	Bus	Function
Video	15-pin DSUB (standard VGA)	PCI	High-resolution/color support for a Super VGA monitor
IDE	None	PCI	Support for internal fast ATA-2 hard drive
Ethernet	RJ-45	PCI	10/100 BaseT Ethernet connection
SCSI	68-pin UW-SCSI	PCI	External connection for hard drives, CD-ROM drives, and so on
GPIB	24-pin CHAMP	ISA	IEEE 488.2 interface compatible with the National Instruments AT-GPIB/TNT
VXI	Two 96-pin DIN (rear of board)	PCI	High-performance VXIbus interface
Serial	Serial Port (Mini DSUB)	ISA	16550 serial ports
Parallel	Parallel Port (IEEE 1284)	ISA	Extended capabilities
USB	Four-wire USB	PCI	Universal Serial Bus device

---

## Functional Overview

This chapter contains functional descriptions of each major logic block on the VXI/VMEpc 600 Series.

### VXI/VMEpc 600 Series Functional Description

---

The VXI/VMEpc 600 Series is a VXI/VMEbus embedded controller in a B-size form factor. It includes many high-performance peripherals that normally require add-in cards on desktop PCs. In addition, it has a VXI/VMEbus interface that is controlled from the PCI local bus, providing extremely high performance and reliability.

Figure 2-1 is a functional block diagram of the VXI/VMEpc 600 Series. Following the diagram is a description of each logic block shown.

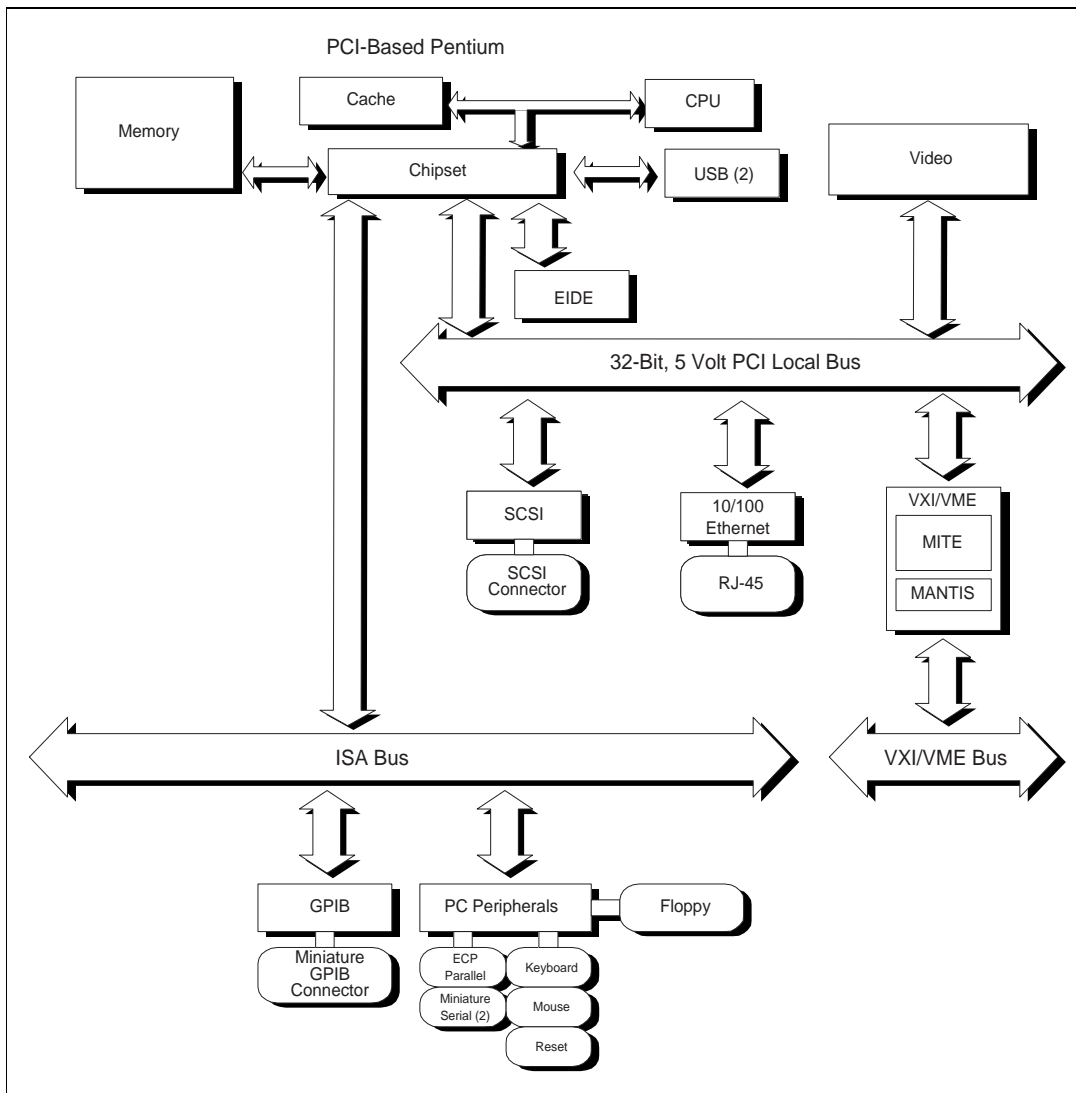

Figure 2-1. VXI/VMEpc 600 Series Block Diagram

The VXI/VMEpc 600 Series consists of the following logic blocks:

<b>Video</b>	The video circuitry is a plug-in PCI card that has a 64-bit data path and 2 MB of EDO DRAM.
<b>IDE</b>	This is dedicated IDE circuitry providing fast ATA-2 transfers to the internal hard drive.
<b>VXI/VME</b>	This is the PCI-VXI/VMEbus interface circuitry. The MITE is a National Instruments ASIC developed to efficiently manage data transfers between the VXI/VMEbus and the processor (via the PCI bus). The MANTIS ASIC (also developed by National Instruments) performs VXI/VMEbus arbitration and manages VXIbus interrupts and triggers. Also part of the VXIbus interface are the SMB connectors, which you can use to route triggers and the CLK10 signal to or from the VXIbus.
<b>Ethernet</b>	This is an PCI-based Ethernet circuit. It uses an RJ-45 connector for access to an external Ethernet 10/100 Base-T LAN.
<b>GPIB</b>	This is the IEEE 488.2 port. It uses the National Instruments TNT4882 ASIC for maximum performance as an ISA-based GPIB controller.
<b>PC Peripherals</b>	These blocks represent the other peripherals supplied by the VXI/VMEpc 600 Series. The VXI/VMEpc 600 Series has PS/2 mouse and keyboard ports, two miniature serial ports, an ECP/EPP parallel port, reset button, and a 1.44 MB, 3.5 in. floppy drive.
<b>System I/O</b>	This block has the bridge between the PCI bus and the ISA bus. It also has PCI bus arbitration logic and integrates PC-specific hardware such as the DMA and interrupt controllers.
<b>SCSI</b>	The SCSI circuitry uses a PCI-SCSI bridge to provide a flexible Ultra Wide SCSI connection on the front panel, usable for such devices as external hard disks and CD-ROM drives.

---

# Configuration and Installation

This chapter contains the instructions to configure and install the VXI/VMEpc 600 Series. Unless otherwise noted, these instructions apply to all models in the VXI/VMEpc 600 Series, which currently consists of the VXIpc-650 and the VMEpc-650.



**Caution** *Electrostatic discharge can damage several components on your VXI/VMEpc 600 Series module. To avoid such damage in handling the module, touch the antistatic plastic package to a metal part of your VXI chassis before removing the module from the package.*

## Default Settings

---

This section summarizes the hardware default settings for the VXI/VMEpc 600 Series for easy reference. The module is set at the factory for the most commonly used configuration.

Figure 3-1 shows the location of the user-configurable jumpers on the VXIpc-650 base board. The figure also shows the location of the serial and assembly numbers.

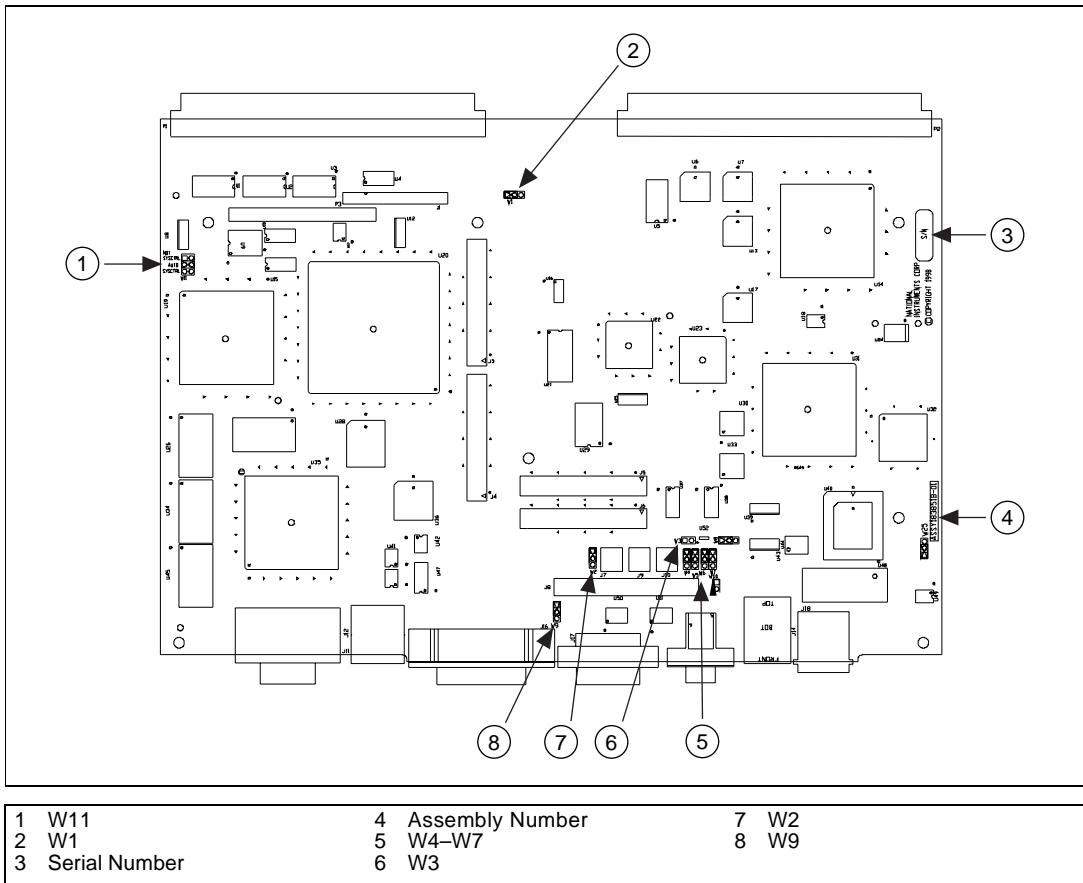

**Figure 3-1.** VXIpc-650 Parts Locator Diagram

Figure 3-2 shows the location of the user-configurable jumpers on the VMEpc-650 base board. The figure also shows the location of the serial and assembly numbers.

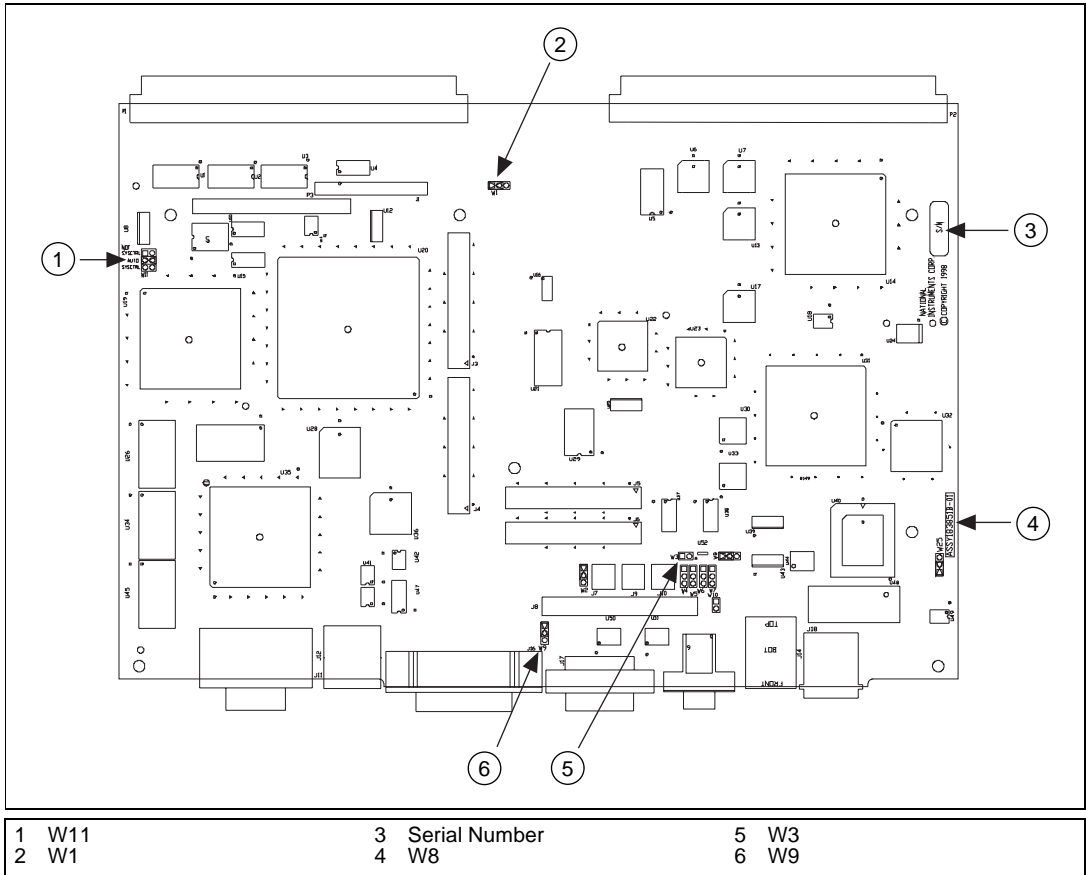

**Figure 3-2.** VMEpc-650 Parts Locator Diagram

One of the user-configurable jumpers, W20, is located on the CPU module attached to the base board. Figure 3-3 shows the location of the W20 jumper, which controls the system CMOS setting. Notice that you do not have to remove the CPU module from the base board to configure any of the jumpers on either board. Refer to the *System CMOS* section later in this chapter for more information.

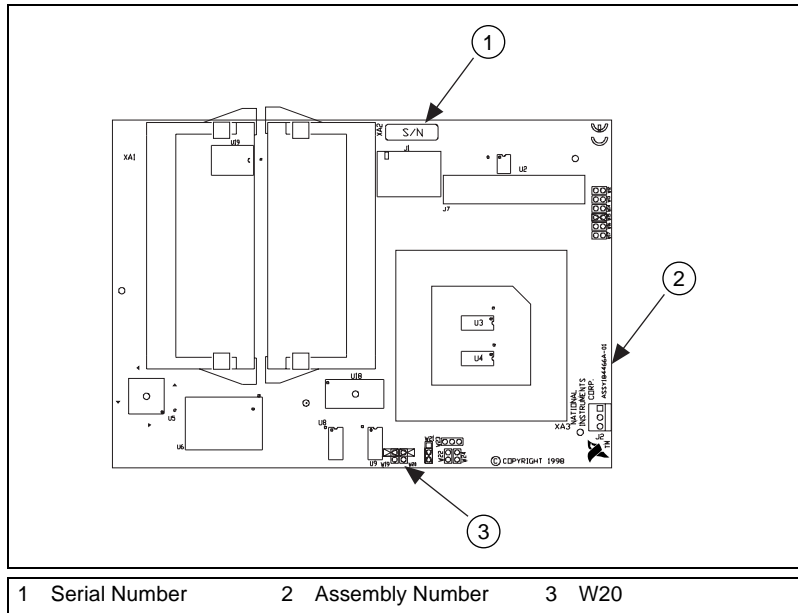

**Figure 3-3.** CPU Module Attached to VXI/VMEpc-650



Table 3-1 lists the factory-default settings and options for the onboard jumpers and switches.

**Table 3-1.** VXI/VMEpc 600 Series Hardware Default Settings

<b>Jumper</b>	<b>Default Setting</b>	<b>Optional Setting</b>
W1	Enable MITE self-configuration	Disable MITE self-configuration
W2	No termination on external trigger input	Terminate external trigger input to 50 $\Omega$
W3	Supply SCSI termination	Disable SCSI termination
W4	Receive CLK10 input from SMB	Source CLK10 output to SMB
W5	No termination on CLK10 input	Terminate CLK10 input to 50 $\Omega$
W6	Source CLK10 from onboard oscillator	Source CLK10 from SMB
W7	Non-inverted CLK10 output	Inverted CLK10 output
W9	MITE user configuration	MITE factory configuration
W11	Enable automatic slot detection	Force System Controller; Force Non-System Cont.
W20	Normal CMOS operation	Clear CMOS



**Note**

*Please do not adjust the jumpers on any jumper blocks not listed in Table 3-1 unless directed by National Instruments support.*

# Configuring the VXI/VMEpc 600 Series

This section describes how to configure the following options on the VXI/VMEpc 600 Series:

- VXI/VMEbus System Controller/Non-System Controller
- VXIbus CLK10 routing (VXIpc only)
- Trigger input termination (VXIpc only)
- MITE EEPROM

## VXI/VMEbus System Controller/Non-System Controller

The VXI/VMEpc 600 Series is configured at the factory to automatically detect if it is installed in Slot 0 of a VXIbus mainframe (or Slot 1 in a VMEbus chassis). With automatic System Controller slot detection, you can install the module into any VXI/VMEbus slot.

You can manually configure the VXI/VMEpc 600 Series for either System Controller or Non-System Controller operation by defeating the automatic-detection circuitry. Use the three-position jumper W11 to select automatic detection, System Controller, or Non-System Controller operation. Figure 3-4 shows these three settings.



**Caution** *Do not install a device configured for System Controller into another slot without first reconfiguring it to either Non-System Controller or automatic-detection configuration. Neglecting to do this could result in damage to the device, the VXI/VMEbus backplane, or both.*

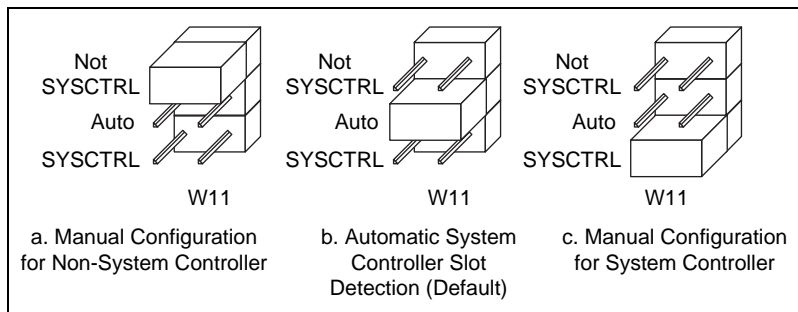

**Figure 3-4.** System Controller Slot Configuration

When the VXI/VMEpc 600 Series is installed in Slot 0 of a VXI system or Slot 1 of a VME system, it becomes the VXI/VMEbus System Controller. In this role, it has VXI/VMEbus Data Transfer Bus Arbiter circuitry that accepts bus requests on all four VXI/VMEbus request levels, prioritizes the requests, and grants the bus to the highest priority requester. As VXI/VMEbus System Controller, the VXI/VMEpc 600 Series also drives the 16 MHz VXI/VMEbus system clock by an onboard 16 MHz oscillator.

- ◆ **VXIpc 600 Series Only**—As required by the VXIbus specification, the VXIpc 600 Series drives the 10 MHz signal CLK10 on a differential ECL output when installed in Slot 0. When not installed in Slot 0, the VXIpc 600 Series only receives the CLK10 signal.

## VXIbus CLK10 Routing (VXIpc 600 Series Only)

When the VXIpc 600 Series is installed in Slot 0 of your mainframe, it supplies the VXIbus CLK10 signal. The VXIpc 600 Series can use two different sources to generate this signal: an onboard oscillator, or the external CLK SMB connector. Use jumper W6 to select these options, as shown in Figure 3-5.



### Note

*Figures 3-5 through 3-8 each highlight one jumper in a block of four jumpers. The other three jumpers are grayed out to focus your attention to the specific jumper.*

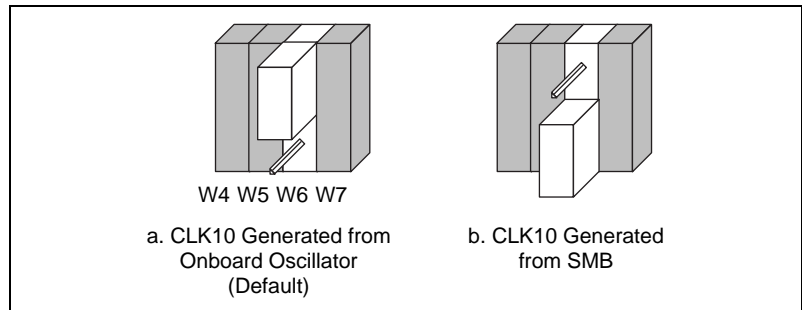

**Figure 3-5.** VXIbus CLK10 Routing

The VXIpc 600 Series can also be configured to drive the external CLK10 SMB from the VXIbus CLK10 signal. Jumper W4 controls whether the VXIpc 600 Series drives or receives the external CLK10 SMB. If you change the W4 setting to drive CLK10 out the external CLK10 SMB connector (Figure 3-6b), do not set W6 to source CLK10 to the backplane from the SMB; instead use the setting shown in Figure 3-5a.

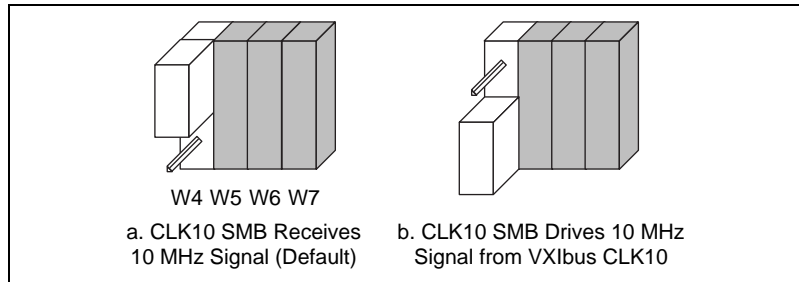

**Figure 3-6.** SMB CLK10 Direction

When jumper W4 is set so that the VXIpc-650 receives the SMB CLK10 signal, you have the option to add a 50  $\Omega$  termination to the signal by setting W5. W5 is unused—its setting does not matter—when W4 is configured to drive the external CLK SMB signal. Figure 3-7 shows the settings for switch W5.

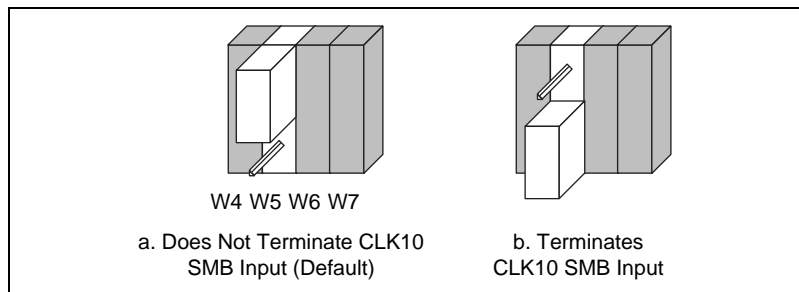

**Figure 3-7.** SMB CLK10 Termination

You can use an additional switch, W7, to control the polarity of the external CLK SMB signal when W4 is configured to drive it. W7 is unused—its setting does not matter—when W4 is configured to receive the external CLK SMB signal.

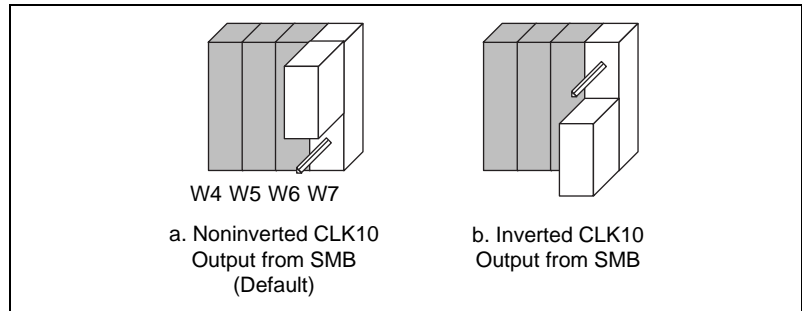

**Figure 3-8.** SMB CLK10 Polarity

## Trigger Input Termination (VXIpc 600 Series Only)

You can use jumper W2 to terminate the external trigger input SMB with 50  $\Omega$  to ground. Figure 3-9a shows the default setting for a non-terminated trigger input SMB. Use the setting of Figure 3-9b to terminate the trigger input SMB.

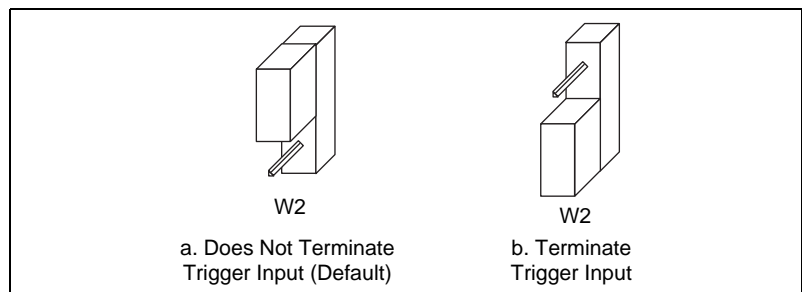

**Figure 3-9.** SMB Trigger Input Termination

## MITE EEPROM

The VXI/VMEpc 600 Series has an onboard EEPROM, which stores default register values for the VXI/VME circuitry. These values are loaded when you power up the computer. These values read from the EEPROM tell the PCI interface of the VXI/VMEbus registers so that the VXI/VME interface is ready to respond to Resource Manager accesses within the required 5 s of SYSRST\* deasserting. You can use jumper W1 to disable this power-on self-configuration (POSC) circuit. Although this makes the VXI/VME circuitry unusable, it is sometimes helpful in debugging address and interrupt conflicts with add-in boards. In general, however, you should leave jumper W1 in its factory-default setting. Figure 3-10 shows the possible configurations for W1.

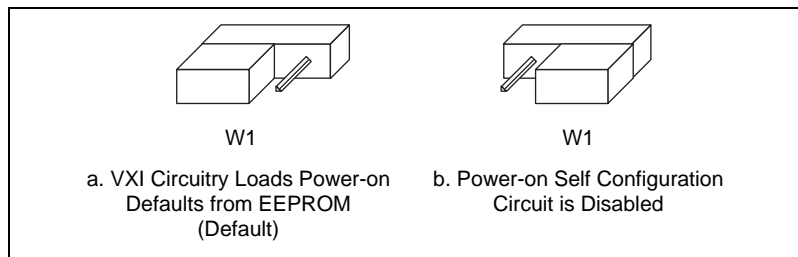

**Figure 3-10.** Power-on Self Configuration Status

The EEPROM is divided into two halves; one half is factory configured and one half is user configurable. Use jumper W9 to control the operation of the EEPROM. The setting of this jumper determines whether the VXI/VMEpc 600 Series boots off the factory-configured half or the user-modified settings. This is useful in the event that the user-configured half of the EEPROM becomes corrupted in such a way that the VXI/VMEpc 600 Series boots to an unusable state. In its default setting, the VXI/VMEpc 600 Series boots off the user-configurable half.

Figure 3-11 shows the configuration settings for EEPROM operation.

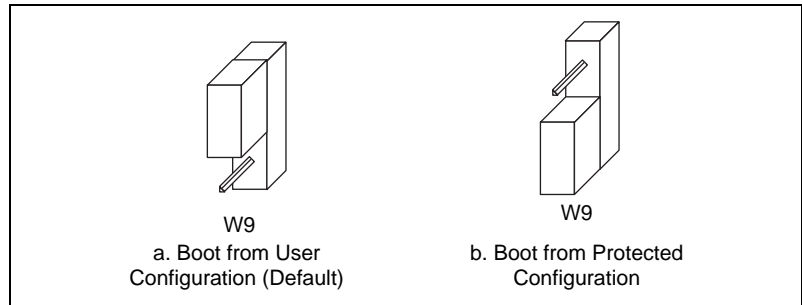

**Figure 3-11.** EEPROM Configuration

## How to Fix an Invalid EEPROM Configuration

The NI-VXI software includes a configuration utility you can use to edit the configuration of the VXI/VMEpc 600 Series. Use T&M Explorer under Windows 95/NT. Some of these settings are stored in files that are read by the NI-VXI software, while other settings are stored directly in the VXI/VMEpc 600 Series EEPROM. Certain EEPROM configurations can lock up your computer while it is booting up. Generally, only the size and location of the memory windows can cause your VXI/VMEpc 600 Series to lock up your system. For example, many PCI-based computers will not boot if a board in its system requests more memory space than the computer can allocate. If you encounter this situation you should reduce the size of the VXI/VMEpc 600 Series user window.

If this situation occurs after you change the configuration, perform the following steps to reconfigure the VXI/VMEpc 600 Series:

1. Turn off your computer.



**Warning** *To protect both yourself and the mainframe from electrical hazards, the mainframe should remain off until you are finished changing the settings on the VXI/VMEpc 600 Series.*

2. Change jumper W9 to the position shown in Figure 3-11 b to restore the factory configuration.
3. Turn on the computer. The computer should boot this time because the factory-default configuration is being used to initialize the VXI/VMEpc 600 Series.
4. Run your software configuration utility to re-adjust the VXI/VMEpc 600 Series configuration.

5. After saving the configuration, exit Windows and turn off the computer.
6. Change jumper W9 to the default position, as shown in Figure 3-11a.
7. Turn on the computer. If the computer does not boot with this configuration, you will have to repeat these steps, modifying your configuration until a final configuration is reached.

## Configuring the PC

This section describes how to configure the following options on the PC:

- SCSI termination
- System CMOS
- Ethernet power-on defaults

### SCSI Termination

The VXI/VMEpc 600 Series uses active termination on the UW-SCSI bus. Because the VXI/VMEpc 600 Series is always an end device, you should not need to disable the termination; however, for informational purposes Figure 3-12 shows the jumper settings for both enabled and disabled termination.

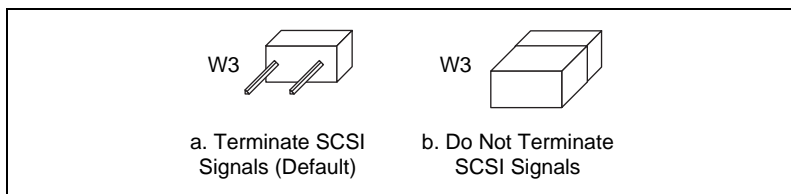

**Figure 3-12.** SCSI Termination

### System CMOS

The VXI/VMEpc-650 contains a backed-up memory used to store BIOS defaults and configuration information:

Follow this procedure to clear the CMOS contents:

1. Place the jumper as shown in Figure 3-13b to short the pins of W20, which is located on the CPU module.



**Caution** *Do not keep these two pins shorted because the CMOS memory cannot be sustained when the power is turned off in this state.*



2. Power-on the VXI/VMEpc-650. The screen should briefly appear, and then go black.
3. Power-off the VXI/VMEpc-650.
4. Remove the jumper as shown in Figure 3-13a to restore normal operation.

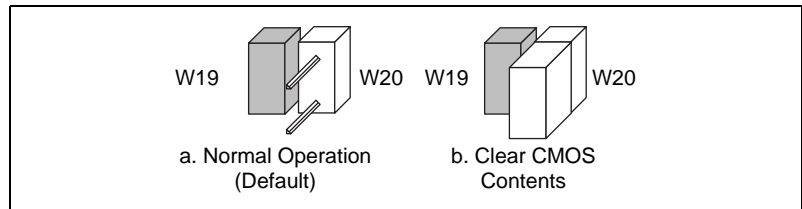

Figure 3-13. System CMOS

## Installing the VXI/VMEpc 600 Series

This section contains general installation instructions for the VXI/VMEpc 600 Series. Consult your VXI/VMEbus mainframe user manual or technical reference manual for specific instructions and warnings.

1. Plug in your mainframe before installing the VXI/VMEpc 600 Series. The power cord grounds the mainframe and protects it from electrical damage while you are installing the module.



**Warning** *To protect both yourself and the mainframe from electrical hazards, the mainframe should remain off until you are finished installing the VXI/VMEpc 600 Series module.*

2. Remove or open any doors or covers blocking access to the mainframe slots.



**Caution** *If the VXI/VMEpc 600 Series is not configured for automatic System Controller detection, be certain that the slot you select in your VXI/VMEbus mainframe matches the VXI/VMEpc 600 Series configuration as either a System Controller device or a Non-System Controller device. Installing the VXI/VMEpc 600 Series into a slot that does not correspond with the jumper setting can damage the VXI/VMEpc 600 Series, the VXI/VMEbus backplane, or both.*

3. Insert the VXI/VMEpc 600 Series in the slot you have selected by aligning the top and bottom of the module with the card-edge guides inside the mainframe. Slowly push the VXI/VMEpc 600 Series straight into the slot until its plug connectors are resting on the

backplane receptacle connectors. Using slow, evenly distributed pressure, press the module straight in until it seats in the expansion slot. The front panel of the VXI/VMEpc 600 Series should be even with the front panel of the mainframe.

4. Tighten the retaining screws on the top and bottom edges of the front panel.
5. Check the installation.
6. Connect the keyboard and mouse to the appropriate connectors. Use the keyboard adapter cable that you received with your kit to adapt AT-style keyboards to the VXI/VMEpc 600 Series mini-DIN connector.
7. Connect the VGA monitor video cable to the VGA connector.
8. Connect devices to ports as required by your system configuration. Some ports, such as the COM ports, have adapter cables that you can order from National Instruments.
9. Replace or close any doors or covers to the mainframe.

---

# BIOS

This chapter contains information on the BIOS (Basic Input Output System), the low-level interface between the hardware and PC software that configures and tests your hardware at boot up. The BIOS has an easy-to-use graphical user interface you use to configure system aspects according to your needs.

## Entering BIOS Setup

---

To enter the BIOS setup program, perform the following steps:

1. Turn on or reboot the system. A screen appears with a series of diagnostic checks.
2. When **Hit <DEL> if you want to run SETUP** appears, press the <DEL> key to enter the BIOS setup program.
3. Choose options with the keyboard. Modify the settings to reflect system options.

## Default BIOS Setup Settings

---

To restore the default settings while inside the BIOS setup program, select either **Auto Configuration with Optimal Settings** or **Auto Configuration with Fail-Safe Settings**.

Select the Optimal settings if you want to get maximum performance from the VXI/VMEpc 600 Series. Fail Safe settings are more conservative settings.

# Specifications

This appendix describes the environmental, electrical, and mechanical specifications of the VXI/VMEpc 600 Series. Unless otherwise specified, these specifications apply to all models in the VXI/VMEpc 600 Series.

## Requirements

Characteristic	Specification
VXIbus Configuration Space	64 KB
A24 or A32 Space	16 KB minimum (programmable)

## Electrical

Voltage (V)	Current (A)	
	Typical	Maximum (Fused)
+5	6.5 A	12 A
-5.2	224.5 mA	2 A
-2	67.2 mA	2 A
+12	112.6 mA	2 A
-12	2.43 mA	2 A

## Physical

---

Characteristic	Specification
Size	Two-slot VXI/VMEbus B-size module
Board Dimensions	233.35 by 160 by 1.6 mm
Weight	2.5 lb typical (16 MB DRAM installed)
Slot Requirements	Two VXI/VME B-size slots
Compatibility	Fully compatible with VXI Specification
VXI Keying Class	Class 1 TTL
MTBF	112,000 hours

## Environmental

---

Characteristic	Specification
Temperature	0° to 50° C functional; -20° to 70° C storage Meets IEC 60068-2-1, 2
Relative Humidity	10% to 90% noncondensing, functional Meets IEC 60068-2-3
EMI	FCC Class A verified, EC verified
Random Vibration	Functional: 5 to 150 Hz @ .01 A.S.D., 1.204 g <sub>RMS</sub> Survival: 10 to 500 Hz @ .02 A.S.D., 3.130 g <sub>RMS</sub> Meets IEC 60068-2-34
Sine Vibration	10 to 60 Hz @ .15 mm displacement, 60 to 500 Hz @ 2 g, survival Meets IEC 60068-2-6
Functional Shock	Half-sine shock pulse (11 ms duration, 30 g peak) Meets IEC 60068-2-27

# VMEbus Capability Codes

Capability Code	Description
A32, A24, A16 (master)	VMEbus master A32, A24, and A16 addressing
A32, A24, A16 (slave)	VMEbus slave A32, A24, and A16 addressing
D64, D32, D16, D08(E0) (master)	VMEbus master D64, D32, D16, and D08 data sizes
D64, D32, D16, D08(E0) (slave)	VMEbus slave D64, D32, D16, and D08 data sizes
BLT, MBLT (master)	VMEbus master block and D64 transfers
BLT, MBLT (slave)	VMEbus slave block and D64 transfers
RMW (master)	VMEbus master read/modify/write transfers
RMW (slave)	VMEbus slave read/modify/write transfers
RETRY (master)	VMEbus master retry support
RETRY (slave)	VMEbus slave retry support
FSD	First slot detector
SCON	VMEbus System Controller (Automatic Detection)
PRI, RRS	Prioritized or Round Robin Select arbiter
ROR, FAIR	Release on Request and FAIR bus requester
IH(7-1)	Interrupt handler for levels 7-1
I(7-1)	Interrupt requester for levels 7-1
D32, D16, D08(O) (Interrupt Handler)	VMEbus D32, D16, D08(O) interrupt handler

<b>Capability Code</b>	<b>Description</b>
D32, D16, D08(O) (Interrupter)	VMEbus D32, D16, D08(O) interrupter
ROAK, RORA	Release on Acknowledge or Register Access interrupter
BTO(x)	VMEbus bus timer (programmable limit)
LOCK	Can lock the VMEbus for indivisible transfers

---

## LED Indicators

This appendix describes how to read the LEDs on the front panel to interpret the status of the VXI/VMEpc 600 Series.

### VXIbus Interface Status LEDs

---

The VXIbus interface status LEDs are located at the top of the module and include four LEDs: **FAIL**, **SYSF**, **ONLINE**, and **TEST**. They indicate the various stages of initialization that occur as the VXI/VMEpc 600 Series boots. The following paragraphs describe each LED.

#### SYSF LED

The **SYSF** LED is lit when the VXI/VMEbus SYSFAIL signal is asserted. It does not necessarily indicate that the VXI/VMEpc 600 Series is asserting SYSFAIL, only that there is a device in the system asserting SYSFAIL.

#### FAIL LED

The **FAIL** LED is lit when the VXI/VMEpc 600 Series is driving the SYSFAIL signal. The VXI/VMEpc 600 Series asserts SYSFAIL when the PASSED bit in its VXIbus status register is clear. The PASSED bit is set by the power-on self configuration circuitry (POSC) when it has completed initializing the VXI/VMEbus interface.

#### ONLINE LED

The **ONLINE** LED is lit when the Resource Manager has successfully completed and the VXI/VMEbus interface is ready for application programs.

#### TEST LED

The **TEST** LED is lit when the power-on self configuration circuitry is configuring the VXI/VMEbus interface.



## LEDs and System Startup Cycle

Table B-1 shows a system startup cycle and possible points of failure, up to and including the state in which the **ONLINE** LED is asserted.

**Table B-1.** LEDs and System Startup Status

Step	LEDs Lit	Status	Possible Problem if VXI/VMEpc 600 Fails
1	None	Machine just turned on.	The VXI/VMEpc 600 Series is not receiving power.
2	<b>FAIL,</b> <b>SYSF</b>	Now asserting SYSFAIL because VXI/VMEbus interface has not been initialized yet.	Power-on self configuration (POSC) cannot execute because of problems with system reset or because the POSCEN switch is incorrectly configured.
3	<b>FAIL,</b> <b>TEST</b>	VXI/VMEbus interface is being initialized by MITE power-on self configuration (POSC) circuitry.	POSC has stalled.
4	<b>TEST</b>	POSC circuitry has initialized VXI/VMEbus interface, setting PASSED and DONE bits.	POSC stalled before clearing the <b>TEST</b> LED.
5	None	POSC cycles are complete. VXI port is ready to respond to Resource Manager inquiries.	POSC completed successfully; however, the Resource Manager either hung or was not executed.
6	<b>ONLINE</b>	Resource Manager has been executed, indicating that the VXI software can now communicate with the VXI/VMEbus circuitry.	Resource Manager interface initialized successfully.

If either the **SYSF** or **FAIL** LED remains lit, perform the following steps:

1. Power off the mainframe.
2. Remove all other modules from the mainframe.
3. Make sure that the VXI/VMEpc 600 Series jumper settings are correct.
4. Make sure that the VXI/VMEpc 600 Series is seated properly in the mainframe.
5. Power on the mainframe and observe whether the **SYSF** and **FAIL** LEDs become unlit some time before the operating system boots.

## Board Access LEDs

---

The board access LEDs—**ACC** and **DRV**—indicate when board resources have been accessed. The following paragraphs describe these LEDs.

### ACC LED

When lit, the **ACC** LED indicates that the VXI/VMEpc 600 Series MODID line is asserted or that another VXI/VMEbus master is accessing VXI/VMEbus shared registers or shared memory.

### DRV LED

The **DRV** LED light indicates that an access to the internal hard disk drive is occurring.

## Ethernet LEDs

---

The Ethernet LEDs (**RX**, **TX**, **LNK**, and **100B-T**) indicate the status of the Ethernet interface on the VXI/VMEpc 600 Series.

### RX LED

The **RX** LED lights when the Ethernet interface is receiving a packet.

### TX LED

The **TX** LED lights when the Ethernet interface is transmitting a packet.

### LNK LED

The **LNK** LED indicates link status, in this case that the controller is connected to a valid Ethernet port.

## 100B-T

The **100B-T** LED indicates that the current Ethernet connection is at 100 Mbits/s when lit.



---

# Front Panel and Connectors

This appendix describes the front panel and connectors on the VXI/VMEpc 600 Series. This material contains the information relevant to VXIplug&play Specification VPP-8, *VXI Module/Mainframe to Receiver Interconnection*.

**Note**

*The illustrations in this appendix show the mating face of the connectors. An asterisk (\*) after a signal name indicates that the signal is active low.*

The VXI/VMEpc 600 Series has the following front panel connectors:

- Two RS-232 Serial
- Extended Capabilities Parallel (ECP)
- SVGA Controller
- IEEE 488.2
- RJ-45 Ethernet
- UW-SCSI
- External Clock (VXIpc-650 only)
- Trigger Output (VXIpc-650 only)
- Trigger Input (VXIpc-650 only)
- PS/2-Style Keyboard
- PS/2-Style Mouse
- Two USB

# Front Panel

Figure C-1 shows the front panel layout of the VXIpc-650, and Figure C-2 shows the layout of the VMEpc-650. The drawings show dimensions relevant to key elements on the front panel. Dimensions are shown in inches and millimeters, with millimeter dimensions in square brackets. The front panel thickness for all models in the VXI/VMEpc 600 Series is 2.49 mm (0.098 in.).

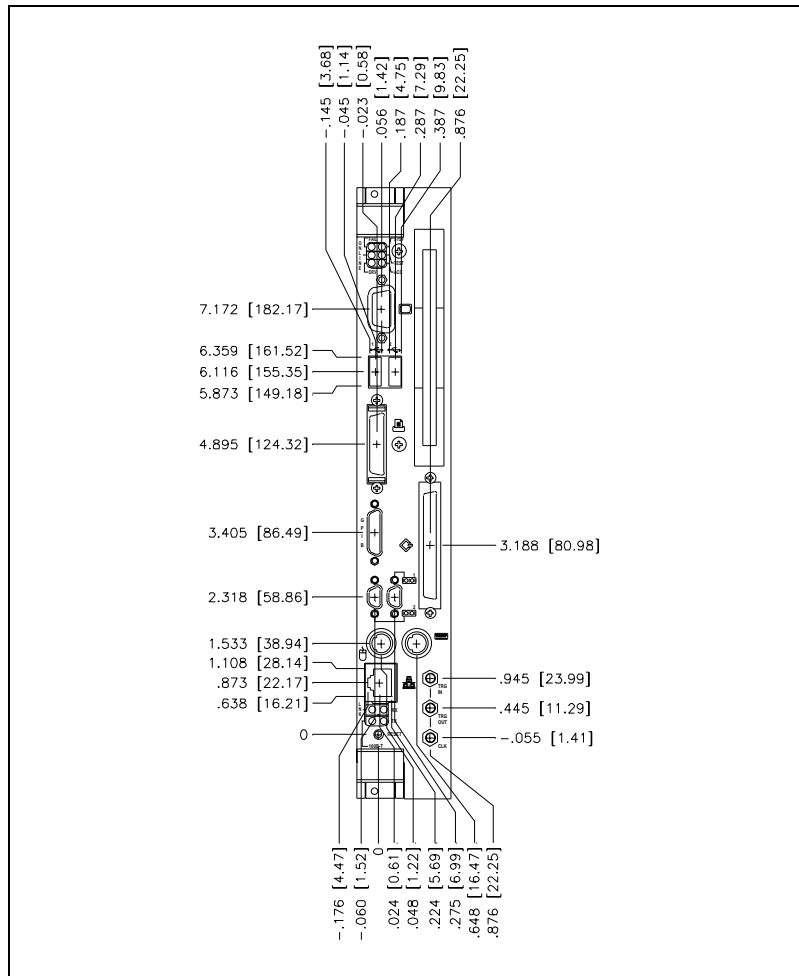

**Figure C-1.** VXIpc-650 Front Panel Layout and Dimensions

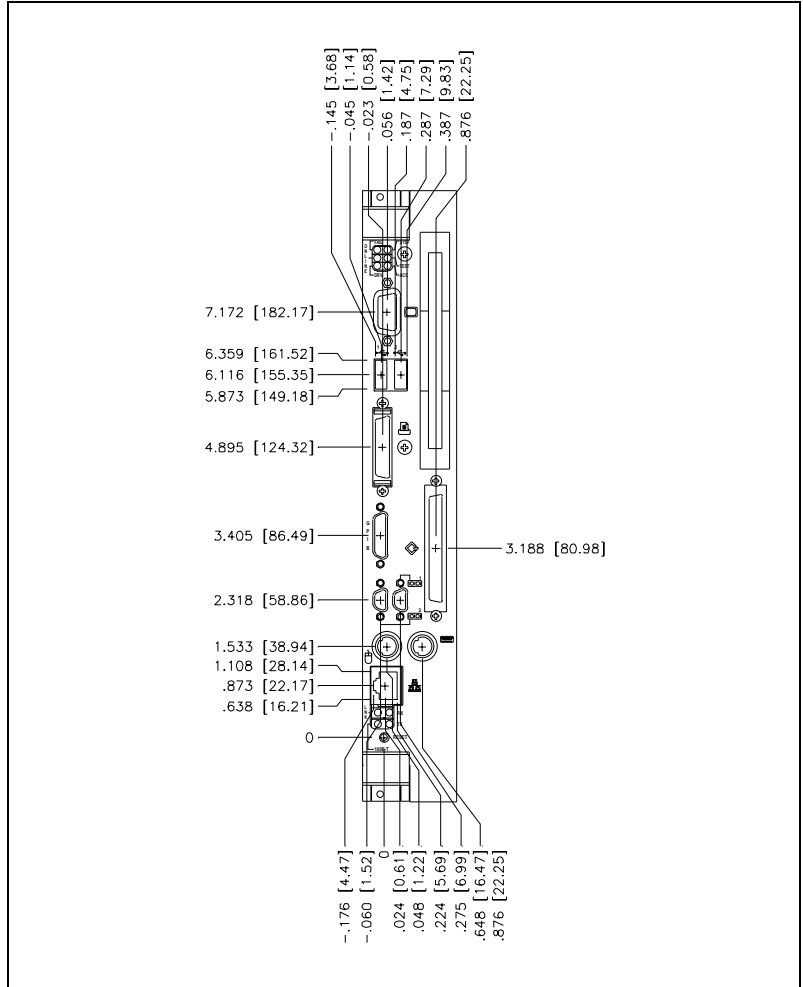
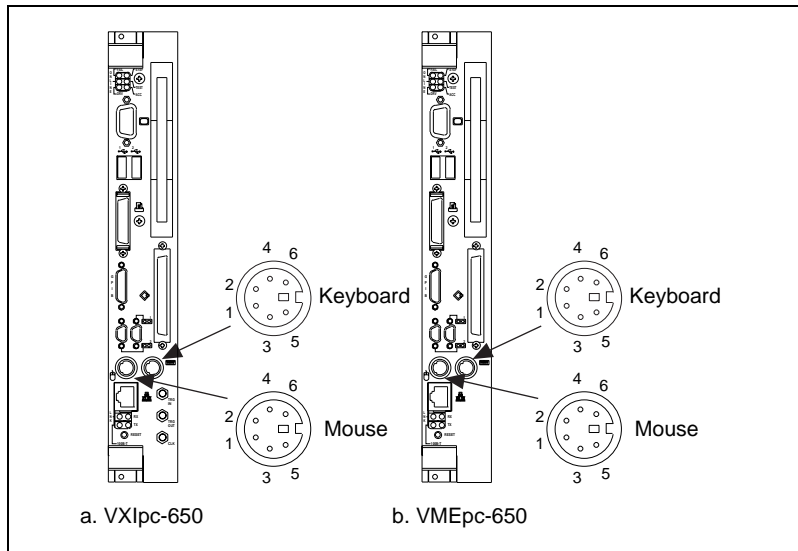

Figure C-2. VMEpc-650 Front Panel Layout and Dimensions

# Keyboard and Mouse

Figure C-3 shows the location and pinouts for the keyboard and mouse connectors on the VXI/VMEpc 600 Series. Table C-1 gives the name and description for the keyboard and mouse connector signals.

Amp manufactures a mating connector with part numbers 212437-4 (housing), 212435-7 (ferrule), and 66735-4 (pin contact).



**Figure C-3.** Keyboard and Mouse Connectors Location and Pinout

**Table C-1.** Keyboard and Mouse Connector Signals

Pin	Signal Name	Signal Description
1	DATA	Data
2	NC	Not Connected
3	GND	Ground
4	+5V	+5 volts
5	CLK	Clock
6	NC	Not Connected

# VGA

Figure C-4 shows the location and pinouts for the VGA connector on the VXI/VMEpc 600 Series. Table C-2 gives the name and description for the VGA connector signals.

Amp manufactures a mating connector with part numbers 748364-1 (housing) and 748333-2 (pin contact).

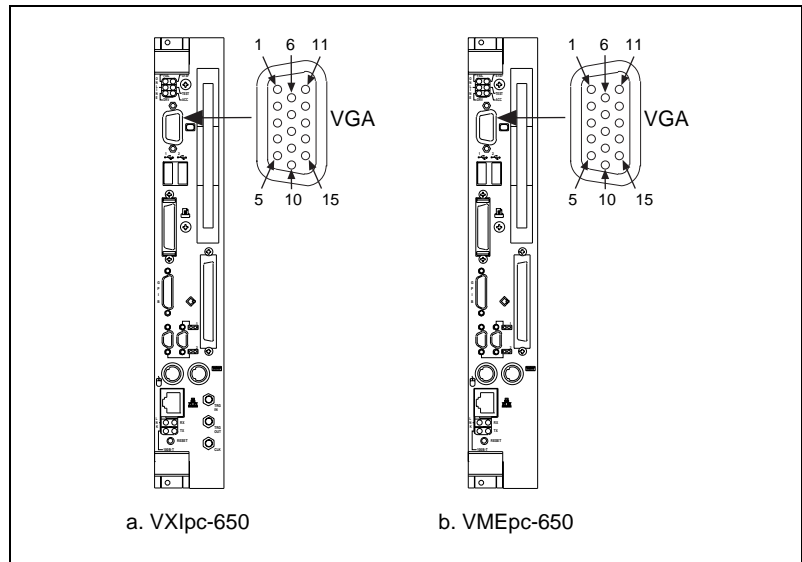

**Figure C-4.** VGA Connector Location and Pinout

**Table C-2.** VGA Connector Signals

Pin	Signal Name	Signal Description
1	R	Red
2	G	Green
3	B	Blue
4	NC	Not Connected
5	GND	Ground
6	GND	Ground
7	GND	Ground
8	GND	Ground



**Table C-2.** VGA Connector Signals (Continued)

Pin	Signal Name	Signal Description
9	NC	Not Connected
10	GND	Ground
11	NC	Not Connected
12	SD	Serial Data
13	HSync	Horizontal Sync
14	VSynC	Vertical Sync
15	SC	Serial Clock

## Ethernet

Figure C-5 shows the location and pinouts for the Ethernet connector on the VXI/VMEpc 600 Series. Table C-3 gives the name and description for the Ethernet connector signals.

Amp manufactures a mating connector, part number 554739-1.

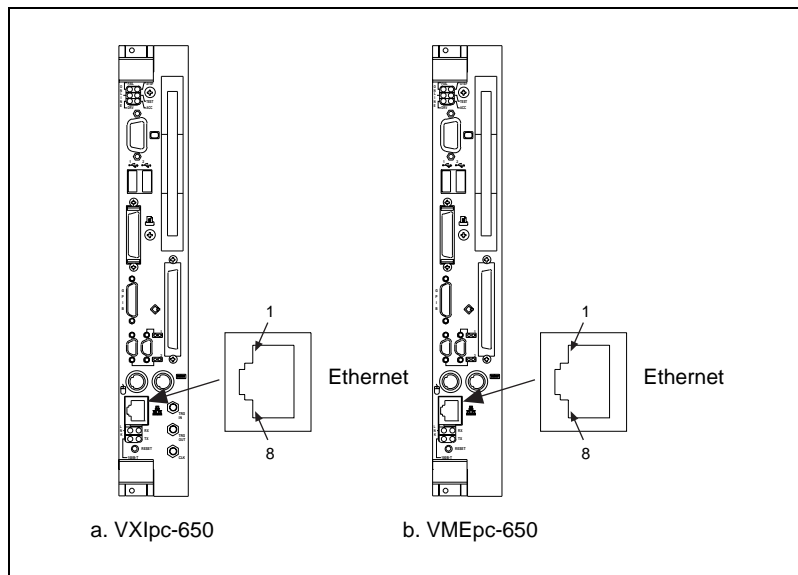
**Figure C-5.** Ethernet Connector Location and Pinout

**Table C-3.** Ethernet Connector Signals

<b>Pin</b>	<b>Signal Description</b>
1	Differential Transmit +
2	Differential Transmit –
3	Differential Receive +
4	NC
5	NC
6	Differential Receive –
7	NC
8	NC

## COM1 and COM2

---

Figure C-6 shows the location and pinouts for the COM1 and COM2 connectors on the VXI/VMEpc 600 Series. Table C-4 gives the name and description for the COM1 and COM2 connector signals.

ITT Cannon manufactures a serial port mating connector, part number MDSM-9SC-Z11, for the COM1 and COM2 connectors.

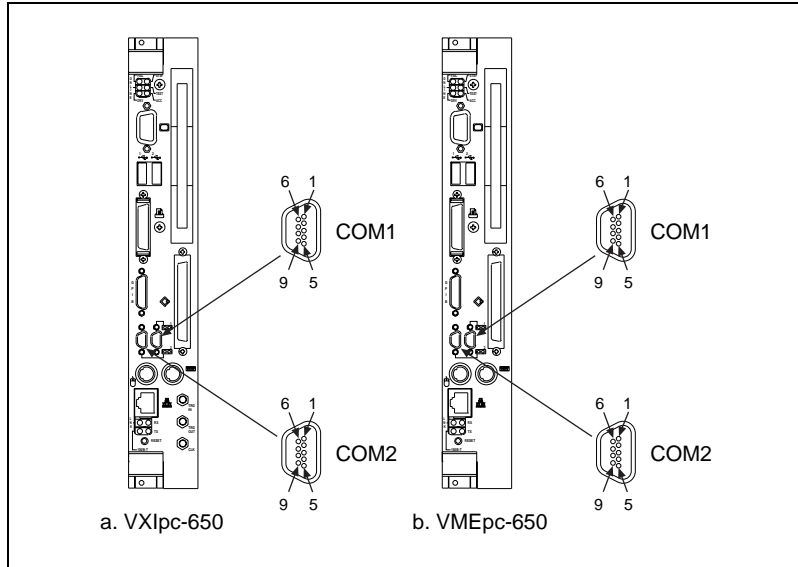

**Figure C-6.** COM1 and COM2 Connectors Location and Pinout

**Table C-4.** COM1 and COM2 Connector Signals

Pin	Signal Name	Signal Description
1	DCD*	Data Carrier Detect
2	RXD*	Receive Data
3	TXD*	Transmit Data
4	DTR*	Data Terminal Ready
5	GND	Ground
6	DSR*	Data Set Ready
7	RTS*	Ready to Send
8	CTS*	Clear to Send
9	RI*	Ring Indicator

# Parallel Port

Figure C-7 shows the location and pinouts for the IEEE-1284 connector on the VXI/VMEpc 600 Series. Table C-5 gives the name and description for the IEEE-1284 connector signals.

Amp manufactures a parallel port compatible connector, part number 2-175677-5.

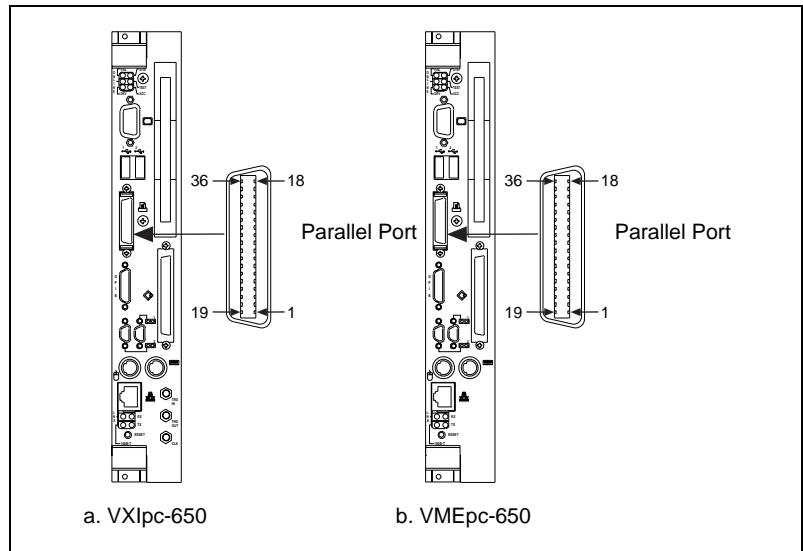

**Figure C-7.** Parallel Port Connector Location and Pinout

**Table C-5.** Parallel Port Connector Signals

<b>Pin</b>	<b>Signal Name</b>	<b>Signal Description</b>
1	BUSY*	Device Busy
2	SLCTIN*	Select Input
3	ACK*	Acknowledge
4	FAULT*	Fault
5	ERROR	Error
6	PD0	Data Bit 0
7	PD1	Data Bit 1
8	PD 2	Data Bit 2
9	PD3	Data Bit 3
10	PD4	Data Bit 4
11	PD5	Data Bit 5
12	PD6	Data Bit 6
13	PD7	Data Bit 7
14	INIT*	Initialize Printer
15	STROBE*	Strobe
16	SLCT	Select
17	AUTOFD	Auto Line Feed
18	+5V	+5 Volts
19-35	GND	Ground
36	NC	Not Connected

# Universal Serial Bus

Figure C-8 shows the location and pinouts for the two Universal Serial Bus (USB) connectors on the VXI/VMEpc 600 Series. Table C-6 gives the name and description for the USB connector signals.

Amp manufactures a mating connector, part number 787633.

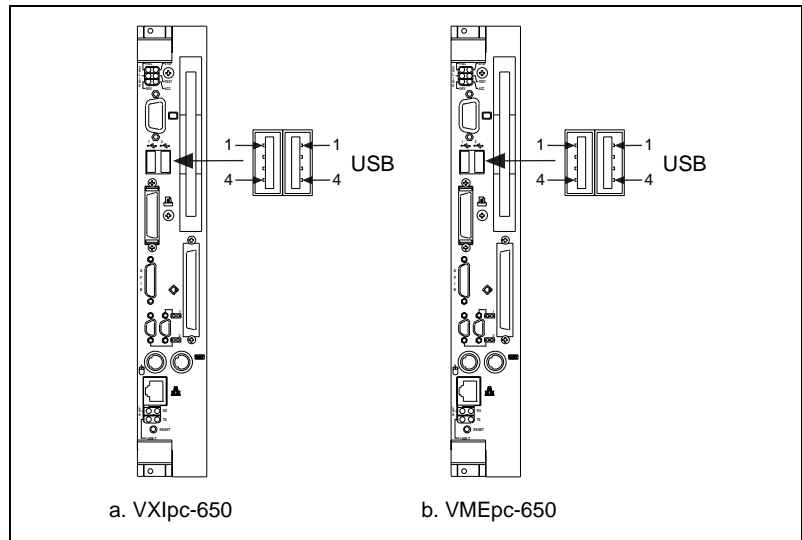

**Figure C-8.** USB Connectors Location and Pinout

**Table C-6.** USB Connector Signals

Pin	Signal Name	Signal Description
1	VCC	Cable Power (+5 V)
2	-Data	USB Data-
3	+Data	USB Data+
4	GND	Ground

# SCSI

Figure C-9 shows the location and pinouts for the SCSI connector on the VXI/VMEpc 600 Series. Table C-7 gives the name and description for the SCSI connector signals.

Amp manufactures a SCSI compatible connector, part number 749111-6, with shielded enclosure 750752-1.

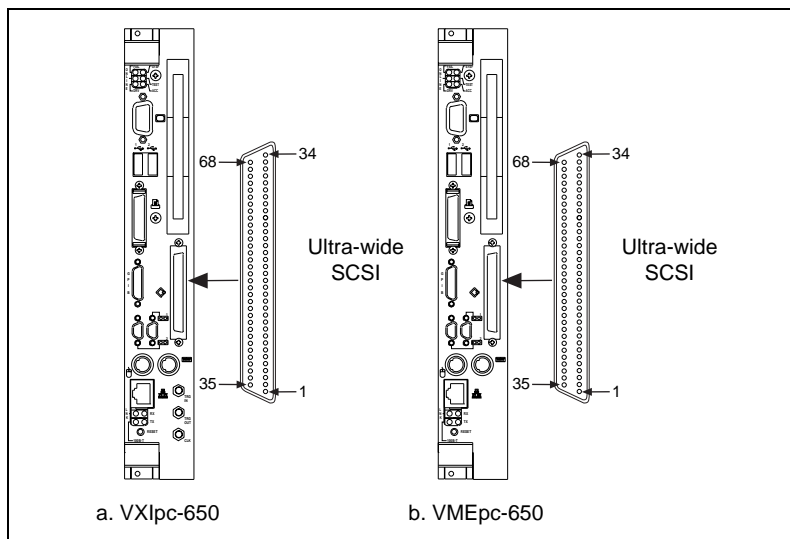

**Figure C-9.** SCSI Connector Location and Pinout

**Table C-7.** 16-Bit Wide SCSI-3 “P” (Primary) Connector Pinout (Single Ended)

SCSI Signal	High Density 68-Pin Connector	SCSI Signal	High Density 68-Pin Connector
GND	1	DB(12)*	35
GND	2	DB(13)*	36
GND	3	DB(14)*	37
GND	4	DB(15)*	38
GND	5	DP1	39
GND	6	DB(0)*	40

**Table C-7.** 16-Bit Wide SCSI-3 “P” (Primary) Connector Pinout  
(Single Ended) (Continued)

SCSI Signal	High Density 68-Pin Connector	SCSI Signal	High Density 68-Pin Connector
GND	7	DB(1)*	41
GND	8	DB(2)*	42
GND	9	DB(3)*	43
GND	10	DB(4)*	44
GND	11	DB(5)*	45
GND	12	DB(6)*	46
GND	13	DB(7)*	47
GND	14	DP0	48
GND	15	GND	49
GND	16	GND	50
TERMPWR	17	TERMPWR	51
TERMPWR	18	TERMPWR	52
RSRVD	19	RSRVD	53
GND	20	GND	54
GND	21	ATN*	55
GND	22	GND	56
GND	23	BSY*	57
GND	24	ACK*	58
GND	25	RST*	59
GND	26	MSG*	60
GND	27	SEL*	61
GND	28	C/D*	62
GND	29	REQ*	63
GND	30	I/O*	64



**Table C-7.** 16-Bit Wide SCSI-3 “P” (Primary) Connector Pinout (Single Ended) (Continued)

SCSI Signal	High Density 68-Pin Connector	SCSI Signal	High Density 68-Pin Connector
GND	31	DB(8)*	65
GND	32	DB(9)*	66
GND	33	DB(10)*	67
GND	34	DB(11)*	68

## GPIB (IEEE-488.2)

Figure C-10 shows the location and pinouts for the GPIB connector on the VXI/VMEpc 600 Series. Table C-8 gives the name and description for the GPIB connector signals.

ITT Cannon manufactures a GPIB mating connector, part number MDSM-255C-Z11.

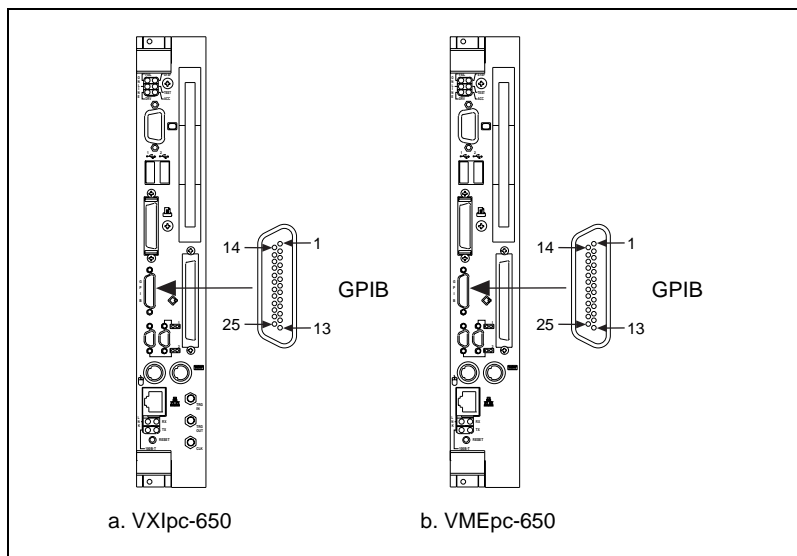

**Figure C-10.** GPIB Connector Location and Pinout

**Table C-8.** GPIB Connector Signals

<b>Pin</b>	<b>Signal Name</b>	<b>Signal Description</b>
1	DIO1*	Data Bit 1
2	DIO2*	Data Bit 2
3	DIO3*	Data Bit 3
4	DIO4*	Data Bit 4
5	EOI*	End or Identify
6	DAV*	Data Valid
7	NRFD*	Not Ready for Data
8	NDAC*	Not Data Accepted
9	IFC*	Interface Clear
10	SRQ*	Service Request
11	ATN*	Attention
12	SHIELD	Chassis ground
13	DIO5*	Data Bit 5
14	DIO6*	Data Bit 6
15	DIO7*	Data Bit 7
16	DIO8*	Data Bit 8
17	REN*	Remote Enable
18-25	GND	Logic Ground

## External SMBs (VXIpc 600 Series Only)

Figure C-11 shows the location and pinouts for the SMB connectors on the VXIpc 600 Series. The SMB connectors are used for an external clock signal and TTL trigger input and output. Table C-9 gives the name and description for the SMB connector signals. Also see Table C-10 for a description of the signal characteristics for the SMB connections.

Amp manufactures an SMB mating connector, part number 1-413985-0.

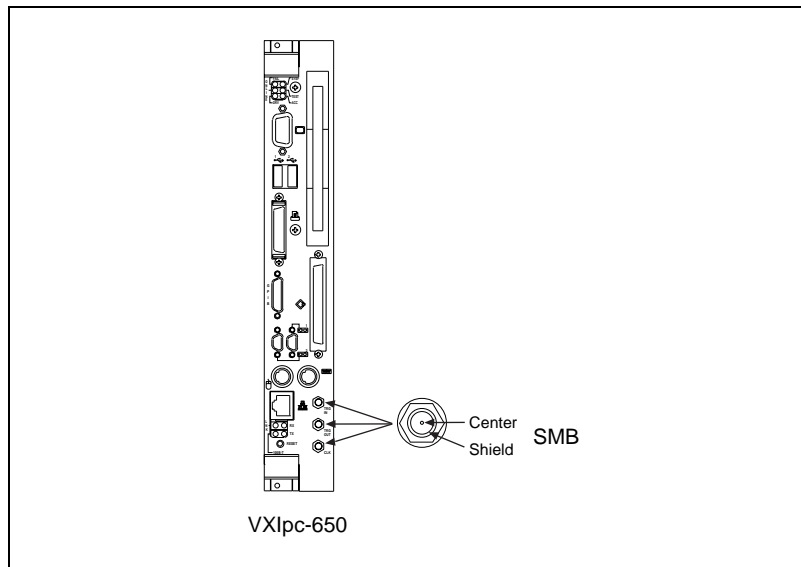

**Figure C-11.** SMB Connectors Location and Pinout

**Table C-9.** SMB Connector Signals

Pin	Signal Description
Center	TTL Trigger or Clock Signal
Shield	Ground

# Signal Characteristics

---

Refer to the relevant standard for the signal characteristics for VGA, SCSI, Ethernet, keyboard, mouse, parallel, serial, and GPIB.

Table C-10 shows the signal characteristics for the SMB connections.

**Table C-10.** Signal Characteristics for SMB Connections

Signal	Voltage Range	Maximum Current	Frequency Range
SMB (TRIG out, CLK out)	0 to 3.4 V	200 mA	DC-10 MHz
SMB (TRIG in)	0 to 5 V	100 mA*	DC-10 MHz
* with 50 $\Omega$ termination			

## VXIbus P1 and P2

Figure C-12 shows the location and pinouts for the VXI/VMEbus connectors on the VXI/VMEpc 600 Series. Notice that the P2 connector is different between the VXI and VME versions. The VME P2 connector connects only to Row B of the P2 connector.

Table C-11 gives the name and description for the VXI/VMEbus P1 connector signals. Table C-12 gives the name and description for the VXIbus P2 connector signals. Table C-13 describes the P2 connector signal assignments on the VMEpc 600 Series.

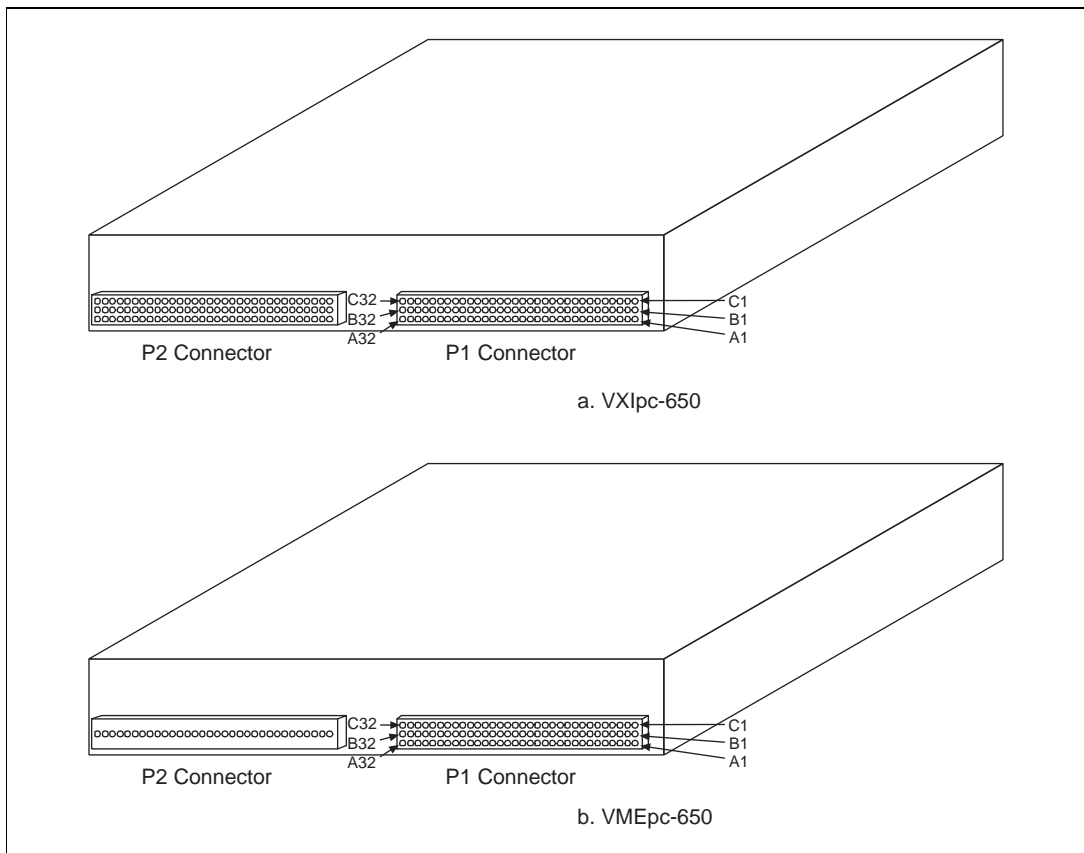

**Figure C-12.** VXIbus Connectors Location and Pinout

**Table C-11.** VXI/VMEbus P1 Connector Signals

<b>Pin</b>	<b>Row C</b>	<b>Row B</b>	<b>Row A</b>
1	D08	BBSY*	D00
2	D09	BCLR*	D01
3	D10	ACFAIL*	D02
4	D11	BG0IN*	D03
5	D12	BG0OUT*	D04
6	D13	BG1IN*	D05
7	D14	BG1OUT*	D06
8	D15	BG2IN*	D07
9	GND	BG2OUT*	GND
10	SYSFAIL*	BG3IN*	SYSCLK
11	BERR*	BG3OUT*	GND
12	SYSRESET*	BR0*	DS1*
13	LWORD*	BR1*	DS0*
14	AM5	BR2*	WRITE*
15	A23	BR3*	GND
16	A22	AM0	DTACK*
17	A21	AM1	GND
18	A20	AM2	AS*
19	A19	AM3	GND
20	A18	GND	IACK*
21	A17	Not Connected	IACKIN*
22	A16	Not Connected	IACKOUT*
23	A15	GND	AM4
24	A14	IRQ7*	A07
25	A13	IRQ6*	A06
26	A12	IRQ5*	A05
27	A11	IRQ4*	A04

**Table C-11.** VXI/VMEbus P1 Connector Signals (Continued)

Pin	Row C	Row B	Row A
28	A10	IRQ3*	A03
29	A09	IRQ2*	A02
30	A08	IRQ1*	A01
31	+12 V	Not Connected	-12 V
32	+5 V	+5 V	+5 V

**Table C-12.** VXIbus P2 Connector Signals

Pin	Row C	Row B	Row A
1	CLK10+	+5 V	ECLTRG0
2	CLK10-	GND	-2 V
3	GND	Retry*	ECLTRG1
4	-5.2 V	A24	GND
5	Not Connected	A25	MODID12
6	Not Connected	A26	MODID11
7	GND	A27	-5.2 V
8	Not Connected	A28	MODID10
9	Not Connected	A29	MODID09
10	GND	A30	GND
11	Not Connected	A31	MODID08
12	Not Connected	GND	MODID07
13	-2 V	+5 V	-5.2 V
14	Not Connected	D16	MODID06
15	Not Connected	D17	MODID05
16	GND	D18	GND
17	Not Connected	D19	MODID04
18	Not Connected	D20	MODID03
19	-5.2 V	D21	-5.2 V

**Table C-12.** VXIbus P2 Connector Signals (Continued)

<b>Pin</b>	<b>Row C</b>	<b>Row B</b>	<b>Row A</b>
20	Not Connected	D22	MODID02
21	Not Connected	D23	MODID01
22	GND	GND	GND
23	TTLTRG1*	D24	TTLTRG0*
24	TTLTRG3*	D25	TTLTRG2*
25	GND	D26	+5 V
26	TTLTRG5*	D27	TTLTRG4*
27	TTLTRG7*	D28	TTLTRG6*
28	GND	D29	GND
29	Not Connected	D30	Not Connected
30	GND	D31	MODID00
31	Not Connected	GND	GND
32	Not Connected	+5 V	Not Connected

**Table C-13.** VMEbus P2 Connector Signals

<b>Pin</b>	<b>Row C</b>	<b>Row B</b>	<b>Row A</b>
1	Not Connected	+5 V	Not Connected
2	Not Connected	GND	Not Connected
3	Not Connected	Retry*	Not Connected
4	Not Connected	A24	Not Connected
5	Not Connected	A25	Not Connected
6	Not Connected	A26	Not Connected
7	Not Connected	A27	Not Connected
8	Not Connected	A28	Not Connected
9	Not Connected	A29	Not Connected
10	Not Connected	A30	Not Connected



**Table C-13.** VMEbus P2 Connector Signals (Continued)

<b>Pin</b>	<b>Row C</b>	<b>Row B</b>	<b>Row A</b>
11	Not Connected	A31	Not Connected
12	Not Connected	GND	Not Connected
13	Not Connected	+5 V	Not Connected
14	Not Connected	D16	Not Connected
15	Not Connected	D17	Not Connected
16	Not Connected	D18	Not Connected
17	Not Connected	D19	Not Connected
18	Not Connected	D20	Not Connected
19	Not Connected	D21	Not Connected
20	Not Connected	D22	Not Connected
21	Not Connected	D23	Not Connected
22	Not Connected	GND	Not Connected
23	Not Connected	D24	Not Connected
24	Not Connected	D25	Not Connected
25	Not Connected	D26	Not Connected
26	Not Connected	D27	Not Connected
27	Not Connected	D28	Not Connected
28	Not Connected	D29	Not Connected
29	Not Connected	D30	Not Connected
30	Not Connected	D31	Not Connected
31	Not Connected	GND	Not Connected
32	Not Connected	+5 V	Not Connected

---

# Common Questions

This appendix answers common questions you may have when using the VXI/VMEpc 600 Series.

## What do the LEDs on the front of the VXI/VMEpc 600 Series mean?

Refer to Appendix B, *LED Indicators*, for a description of the front panel LEDs.

## Is something wrong with the VXI/VMEpc 600 Series if the red SYSF and FAIL LEDs stay lit after booting the VXI/VMEpc 600 Series?

If either the **SYSF** or **FAIL** LED remains lit, refer to Appendix B, *LED Indicators*, for troubleshooting steps.

## Can I access 32-bit registers in my VXI/VMEbus system from the VXI/VMEpc 600 Series?

Yes. The VXI/VMEpc 600 Series uses the 32-bit PCI bus to interface to the VXI/VMEbus. In fact, its VXI/VMEbus circuitry also supports the new VME64 standard for D64 accesses.

## What kind of signal is CLK10 and what kind of signal do I need for an external CLK10?

- ◆ **VXI Only**—CLK10 is a differential ECL signal on the backplane. However, the oscillator and the EXTCLK input on the front panel use TTL levels; therefore, you need to supply a TTL-level signal for EXTCLK. Our voltage converters convert the signal to differential ECL.

## What is the accuracy of the CLK10 signal?

- ◆ **VXI Only**—The CLK10 signal generated by the VXIpc 600 Series is  $\pm 100$  ppm (0.01%) as per the VXIbus specification. If you need a more accurate CLK10 signal, you can use the external CLK connector on the front panel.

### **What if my keyboard connector does not fit into the keyboard port on the VXI/VMEpc 600 Series?**

You can plug keyboards that have a 6-pin Mini DIN PS/2 type connector directly into the VXI/VMEpc 600 Series. You can use the keyboard adapter cable that is included with every VXI/VMEpc 600 Series kit to adapt the larger AT keyboard connector to the 6-pin Mini DIN connector.

### **What must I do if I want to install the VXI/VMEpc-650 in a slot other than the System Controller slot?**

The VXI/VMEpc 600 Series automatically detects whether it is in the System Controller slot (first slot) of a VXI/VMEbus mainframe. You do not need to change jumper settings to install the VXI/VMEpc controller in a different slot unless you have defeated the first slot detector (FSD) circuitry by changing the appropriate jumper setting on the VXI/VMEpc.

Remember that devices in all other slots must not be manually configured as system controller; they should be configured either for automatic detection or manual non-System Controller.

Refer to Chapter 3, *Configuration and Installation*, for information on enabling and defeating the FSD circuitry.

### **How do I check the configuration of the memory, floppy drive, hard drive, time/date, and so on?**

You can view these parameters in the BIOS setup. To enter the BIOS setup, reboot the VXI/VMEpc 600 Series and press the <DEL> key during the memory tests. Refer to Chapter 4, *BIOS*, for more information.

### **How can I boot from an external SCSI hard drive?**

1. Enter the BIOS setup by pressing the <DEL> key during the memory test.
2. Select **Standard CMOS Setup**.
3. Press the down arrow key until the **Pri Master** field is highlighted, and set it to **Not Installed**.
4. Press <ESC> and move the cursor to **Save Settings and Exit**. Press <Enter> twice.



**Note**

*You will not be able to access the internal IDE hard drive in this configuration.*

**Can I use the internal IDE drive and an external SCSI hard drive at the same time?**

Yes, but you can only boot from the internal IDE drive in this configuration.

**My CMOS is corrupted. How do I set it back to default?**

1. Enter the BIOS setup program as described in Chapter 4, *BIOS*.
2. Select **Auto Configuration with Optimal Settings**.
3. Answer **Y** (yes) to the verification prompt.
4. Select **Save Settings and Exit**.

**Why does the SCSI BIOS load twice during bootup?**

The VXI/VMEpc 600 Series is a dual controller. The PCI BIOS detects both functions of the VXI/VMEpc 600 Series and tries to load a ROM extension for each function. This usually occurs only when there are no SCSI devices attached to the VXI/VMEpc 600 Series.

---

# Customer Communication

For your convenience, this appendix contains forms to help you gather the information necessary to help us solve your technical problems and a form you can use to comment on the product documentation. When you contact us, we need the information on the Technical Support Form and the configuration form, if your manual contains one, about your system configuration to answer your questions as quickly as possible.

National Instruments has technical assistance through electronic, fax, and telephone systems to quickly provide the information you need. Our electronic services include a bulletin board service, an FTP site, a fax-on-demand system, and e-mail support. If you have a hardware or software problem, first try the electronic support systems. If the information available on these systems does not answer your questions, we offer fax and telephone support through our technical support centers, which are staffed by applications engineers.

## Electronic Services

### Bulletin Board Support

National Instruments has BBS and FTP sites dedicated for 24-hour support with a collection of files and documents to answer most common customer questions. From these sites, you can also download the latest instrument drivers, updates, and example programs. For recorded instructions on how to use the bulletin board and FTP services and for BBS automated information, call 512 795 6990. You can access these services at:

United States: 512 794 5422

Up to 14,400 baud, 8 data bits, 1 stop bit, no parity

United Kingdom: 01635 551422

Up to 9,600 baud, 8 data bits, 1 stop bit, no parity

France: 01 48 65 15 59

Up to 9,600 baud, 8 data bits, 1 stop bit, no parity

### FTP Support

To access our FTP site, log on to our Internet host, `ftp.natinst.com`, as anonymous and use your Internet address, such as `joesmith@anywhere.com`, as your password. The support files and documents are located in the `/support` directories.

## Fax-on-Demand Support

Fax-on-Demand is a 24-hour information retrieval system containing a library of documents on a wide range of technical information. You can access Fax-on-Demand from a touch-tone telephone at 512 418 1111.

## E-Mail Support (Currently USA Only)

You can submit technical support questions to the applications engineering team through e-mail at the Internet address listed below. Remember to include your name, address, and phone number so we can contact you with solutions and suggestions.

support@natinst.com

## Telephone and Fax Support

National Instruments has branch offices all over the world. Use the list below to find the technical support number for your country. If there is no National Instruments office in your country, contact the source from which you purchased your software to obtain support.

<b>Country</b>	<b>Telephone</b>	<b>Fax</b>
Australia	03 9879 5166	03 9879 6277
Austria	0662 45 79 90 0	0662 45 79 90 19
Belgium	02 757 00 20	02 757 03 11
Brazil	011 288 3336	011 288 8528
Canada (Ontario)	905 785 0085	905 785 0086
Canada (Quebec)	514 694 8521	514 694 4399
Denmark	45 76 26 00	45 76 26 02
Finland	09 725 725 11	09 725 725 55
France	01 48 14 24 24	01 48 14 24 14
Germany	089 741 31 30	089 714 60 35
Hong Kong	2645 3186	2686 8505
Israel	03 6120092	03 6120095
Italy	02 413091	02 41309215
Japan	03 5472 2970	03 5472 2977
Korea	02 596 7456	02 596 7455
Mexico	5 520 2635	5 520 3282
Netherlands	0348 433466	0348 430673
Norway	32 84 84 00	32 84 86 00
Singapore	2265886	2265887
Spain	91 640 0085	91 640 0533
Sweden	08 730 49 70	08 730 43 70
Switzerland	056 200 51 51	056 200 51 55
Taiwan	02 377 1200	02 737 4644
United Kingdom	01635 523545	01635 523154
United States	512 795 8248	512 794 5678

# Technical Support Form

Photocopy this form and update it each time you make changes to your software or hardware, and use the completed copy of this form as a reference for your current configuration. Completing this form accurately before contacting National Instruments for technical support helps our applications engineers answer your questions more efficiently.

If you are using any National Instruments hardware or software products related to this problem, include the configuration forms from their user manuals. Include additional pages if necessary.

Name \_\_\_\_\_

Company \_\_\_\_\_

Address \_\_\_\_\_

\_\_\_\_\_

Fax ( \_\_\_\_ ) \_\_\_\_\_ Phone ( \_\_\_\_ ) \_\_\_\_\_

Computer brand \_\_\_\_\_ Model \_\_\_\_\_ Processor \_\_\_\_\_

Operating system (include version number) \_\_\_\_\_

Clock speed \_\_\_\_\_ MHz RAM \_\_\_\_\_ MB Display adapter \_\_\_\_\_

Mouse \_\_\_yes \_\_\_no Other adapters installed \_\_\_\_\_

Hard disk capacity \_\_\_\_\_ MB Brand \_\_\_\_\_

Instruments used \_\_\_\_\_

\_\_\_\_\_

National Instruments hardware product model \_\_\_\_\_ Revision \_\_\_\_\_

Configuration \_\_\_\_\_

National Instruments software product \_\_\_\_\_ Version \_\_\_\_\_

Configuration \_\_\_\_\_

The problem is: \_\_\_\_\_

\_\_\_\_\_

\_\_\_\_\_

\_\_\_\_\_

\_\_\_\_\_

List any error messages: \_\_\_\_\_

\_\_\_\_\_

\_\_\_\_\_

The following steps reproduce the problem: \_\_\_\_\_

\_\_\_\_\_

\_\_\_\_\_

\_\_\_\_\_

\_\_\_\_\_

# VXI/VMEpc 600 Series Hardware and Software Configuration Form

Record the settings and revisions of your hardware and software on the line to the right of each item. Complete a new copy of this form each time you revise your software or hardware configuration, and use this form as a reference for your current configuration. Completing this form accurately before contacting National Instruments for technical support helps our applications engineers answer your questions more efficiently.

## National Instruments Products

NI-VXI/VISA Software Version Number \_\_\_\_\_

NI-488.2M Software Version Number \_\_\_\_\_

Using Both NI-VXI and NI-VISA? \_\_\_\_\_

Using LabVIEW or LabWindows/CVI? \_\_\_\_\_

## VXI/VMEpc 600 Series Hardware Settings

VXIpc 600 or VMEpc 600 Series Model Number \_\_\_\_\_

Part Number \_\_\_\_\_

Serial Number \_\_\_\_\_

Hard Drive Size \_\_\_\_\_ Video Memory \_\_\_\_\_

Processor Speed \_\_\_\_\_

Slot Location \_\_\_\_\_

W1 Setting: MITE Self-Configuration \_\_\_\_\_

W2 Setting: External Trigger SMB Termination \_\_\_\_\_

W3 Setting: SCSI Termination \_\_\_\_\_

W4 Setting: CLK10 SMB Direction \_\_\_\_\_

W5 Setting: CLK10 SMB Termination \_\_\_\_\_

W6 Setting: CLK10 Source \_\_\_\_\_

W7 Setting: CLK10 SMB Polarity \_\_\_\_\_

W9 Setting: MITE Configuration EEPROM \_\_\_\_\_

W11 Setting: System Controller Slot Detection \_\_\_\_\_

W20 Setting: CMOS Clear \_\_\_\_\_



## Other Products

Computer make and model \_\_\_\_\_

Microprocessor \_\_\_\_\_

Clock frequency or speed \_\_\_\_\_

Type of video board installed \_\_\_\_\_

Operating system version \_\_\_\_\_

Operating system mode \_\_\_\_\_

Programming language \_\_\_\_\_

Programming language version \_\_\_\_\_

Other boards in system \_\_\_\_\_

Base I/O address of other boards \_\_\_\_\_

DMA channels of other boards \_\_\_\_\_

Interrupt level of other boards \_\_\_\_\_

# Documentation Comment Form

National Instruments encourages you to comment on the documentation supplied with our products. This information helps us provide quality products to meet your needs.

**Title:** *VXI/VMEpc™ 600 Series User Manual*

**Edition Date:** May 1998

**Part Number:** 321881A-01

Please comment on the completeness, clarity, and organization of the manual.

---

---

---

---

---

---

---

---

If you find errors in the manual, please record the page numbers and describe the errors.

---

---

---

---

---

---

---

---

Thank you for your help.

Name \_\_\_\_\_

Title \_\_\_\_\_

Company \_\_\_\_\_

Address \_\_\_\_\_

E-Mail Address \_\_\_\_\_

Phone ( \_\_\_\_ ) \_\_\_\_\_ Fax ( \_\_\_\_ ) \_\_\_\_\_

**Mail to:** Technical Publications  
National Instruments Corporation  
6504 Bridge Point Parkway  
Austin, Texas 78730-5039

**Fax to:** Technical Publications  
National Instruments Corporation  
512 794 5678

# Glossary

---

Prefix	Meanings	Value
p-	pico	$10^{-12}$
n-	nano-	$10^{-9}$
$\mu$ -	micro-	$10^{-6}$
m-	milli-	$10^{-3}$
k-	kilo-	$10^3$
M-	mega-	$10^6$
G-	giga-	$10^9$
t-	tera-	$10^{12}$

## Symbols

° degrees

$\Omega$  ohms

## A

A amperes

A24 space VXIbus address space equivalent to the VME 16 MB standard address space

A32 space VXIbus address space equivalent to the VME 4 GB extended address space

address character code that identifies a specific location (or series of locations) in memory

address space	a set of $2^n$ memory locations differentiated from other such sets in VXI/VMEbus systems by six addressing lines known as address modifiers. $n$ is the number of address lines required to uniquely specify a byte location in a given space. Valid numbers for $n$ are 16, 24, and 32. In VME/VXI, because there are six address modifiers, there are 64 possible address spaces.
ANSI	American National Standards Institute
API	Application Programming Interface; the direct interface that an end user sees when creating an application
ASD	Acceleration Spectral Density; a calculation of random vibration intensity across a frequency bandwidth
ASIC	application-specific integrated circuit—a proprietary semiconductor component designed and manufactured to perform a set of specific functions for a specific customer
<b>B</b>	
b	bit—one binary digit, either 0 or 1
B	byte—eight related bits of data, an 8-bit binary number. Also used to denote the amount of memory required to store one byte of data.
backplane	an assembly, typically a printed circuit board, with 96-pin connectors and signal paths that bus the connector pins. A C-size VXIbus system will have two sets of bused connectors called J1 and J2. A D-size VXIbus system will have three sets of bused connectors called J1, J2, and J3.
BERR*	bus error signal
BIOS	Basic Input/Output System. BIOS functions are the fundamental level of any PC or compatible computer. BIOS functions embody the basic operations needed for successful use of the computer's hardware resources.
bus	the group of conductors that interconnect individual circuitry in a computer. Typically, a bus is the expansion vehicle to which I/O or other devices are connected. Examples of buses include the ISA bus, PCI bus, VXI bus, and VME bus.

bus error                    an error that signals failed access to an address. Bus errors occur with low-level accesses to memory and usually involve hardware with bus mapping capabilities. For example, nonexistent memory, a nonexistent register, or an incorrect device access can cause a bus error.

## C

C                                Celsius

CLK10                        a 10 MHz,  $\pm 100$  ppm, individually buffered (to each module slot), differential ECL system clock that is sourced from Slot 0 of a VXIbus mainframe and distributed to Slots 1 through 12 on P2. It is distributed to each slot as a single-source, single-destination signal with a matched delay of under 8 ns.

CMOS                         Complementary Metal Oxide Semiconductor; a process used in making chips

## D

DIN                            Deutsches Institut für Normung—German Standards Institute

DMA                          Direct Memory Access; a method by which data is transferred between devices and internal memory without intervention of the central processing unit. DMA is the fastest method of transferring data to/from computer memory.

DRAM                        Dynamic RAM (Random Access Memory); storage that the computer must refresh at frequent intervals

## E

ECL                            Emitter-Coupled Logic

EEPROM                     Electronically Erasable Programmable Read Only Memory—ROM that can be erased with an electrical signal and reprogrammed

embedded controller      an intelligent CPU (controller) interface plugged directly into the VXI backplane, giving it direct access to the VXIbus. It must have all of its required VXI interface capabilities built in.

EMC	electromagnetic compliance
EMI	electromagnetic interference
external trigger	a voltage pulse from an external source that triggers an event

## F

fair requester	a VXIbus device that will not arbitrate for the VXIbus after releasing it until it detects the bus request signal inactive. This ensures that all requesting devices will be granted use of the bus.
----------------	--

## G

g	<ol style="list-style-type: none"><li>1. grams</li><li>2. A measure of acceleration equal to 9.8 m/s<sup>2</sup></li></ol>
GPIB	General Purpose Interface Bus (IEEE 488)
$g_{\text{RMS}}$	A measure of random vibration. The root mean square of acceleration levels in a random vibration test profile.

## H

hex	hexadecimal; the numbering system with base 16, using the digits 0 to 9 and letters A to F
Hz	hertz; cycles per second

## I

IDE	Integrated Drive Electronics. Denotes the most common interface to the hard drive on PCs.
IEC	International Electrotechnical Commission. The IEC publishes internationally recognized standards. IEC 60068 contains information on environmental testing procedures and severities.
IEEE	Institute of Electrical and Electronics Engineers
in.	inches

I/O	input/output; the techniques, media, and devices used to achieve communication between machines and users
instrument driver	a set of routines designed to control a specific instrument or family of instruments, and any necessary related files for LabWindows/CVI or LabVIEW
interrupt	a means for a device to request service from another device; a computer signal indicating that the CPU should suspend its current task to service a designated activity
interrupt handler	a VMEbus functional module that detects interrupt requests generated by interrupters and responds to those requests by requesting status and identify information
interrupt level	the relative priority at which a device can interrupt
IRQ*	interrupt signal
ISA	Industry Standard Architecture; denotes a common expansion bus used in PCs
<b>K</b>	
K	kilo—(1) the standard metric prefix for 1,000, or $10^3$ , used with units of measure such as volts, hertz, and meters; (2) the prefix for 1,024, or $2^{10}$ , used with B (byte) in quantifying data or computer memory
<b>L</b>	
LED	light-emitting diode
<b>M</b>	
m	meters
M	mega—(1) the standard metric prefix for 1 million or $10^6$ , when used with units of measure such as volts and hertz; (2) the prefix for 1,048,576, or $2^{20}$ , when used with B (byte) to quantify data or computer memory
MANTIS	a National Instruments custom ASIC that performs VXIbus arbitration and manages interrupts and triggers

master	a functional part of a VME/VXIbus device that initiates data transfers on the backplane. A transfer can be either a read or a write.
MBLT	eight-byte block transfers in which both the Address bus and the Data bus are used to transfer data
MITE	a National Instruments custom ASIC, a sophisticated dual-channel DMA controller that incorporates the Synchronous MXI and VME64 protocols to achieve high-performance block transfer rates
MODID	module ID lines. Used in VXI to geographically locate boards and to dynamically configure boards
MTBF	Mean Time Between Failure

## **N**

NI-488.2 or NI-488.2M	the National Instruments industry-standard software for controlling GPIB instruments
NI-VISA	the National Instruments implementation of the VISA standard; an interface-independent software that provides a unified programming interface for VXI, GPIB, and serial instruments
NI-VXI	the National Instruments bus interface software for VME/VXIbus systems
Non-Slot 0 device	a device configured for installation in any slot in a VXIbus mainframe other than Slot 0. Installing such a device into Slot 0 can damage the device, the VXIbus backplane, or both.

## **P**

PCI	Peripheral Component Interconnect. The PCI bus is a high-performance 32-bit or 64-bit bus with multiplexed address and data lines.
PCMCIA	Personal Computer Memory Card International Association
POSC	Power-On Self Configuration. A process by which the MITE chip programs its own registers from EEPROMs at power up



**R**

**Resource Manager** a message-based Commander located at Logical Address 0, which provides configuration management services such as address map configuration, Commander and Servant mappings, and self-test and diagnostic management

**RMS** Root mean squared. See *gRMS*.

**S**

**s** seconds

**SCSI** Small Computer System Interface (bus)

**slave** a functional part of a VME/VXibus device that detects data transfer cycles initiated by a VMEbus master and responds to the transfers when the address specifies one of the device's registers

**SMB** Sub Miniature Type B connector that features a snap coupling for fast connection

**SYSFAIL** A VMEbus signal that is used by a device to indicate an internal failure. A failed device asserts this line. In VXI, a device that fails also clears its PASSEd bit in its Status register.

**System Controller** a device configured for installation in Slot 0 of a VXibus mainframe or Slot 1 of a VMEbus chassis. This device is unique in the VXI/VMEbus system in that it performs the VXI/VMEbus System Controller functions, including clock sourcing and arbitration for data transfers across the backplane. Installing such a device into any other slot can damage the device, the VXI/VMEbus backplane, or both.

**T**

**trigger** either TTL or ECL lines used for intermodule communication

**TTL** Transistor-Transistor Logic

## U

USB	Universal Serial Bus
user window	a region of PCI address space reserved by the hardware for use via the NI-VXI low-level function calls
UW SCSI	Ultra Wide SCSI

## V

V	volts
VGA	Video Graphics Array; the minimum video display standard for all PCs
VISA	Virtual Instrument Software Architecture. This is the general name given to VISA and its associated architecture.
VME	Versa Module Eurocard or IEEE 1014
VMEbus System Controller	a device configured for installation in Slot 1 of a VMEbus chassis. This device is unique in the VMEbus system in that it performs the VMEbus System Controller functions, including clock sourcing and arbitration for data transfers across the backplane. Installing such a device into any other slot can damage the device, the VMEbus backplane, or both.
VXIbus	VMEbus Extensions for Instrumentation

# Index

---

## Numbers

100B-T LED, B-4

## A

ACC LED, B-3

application-specific interface chips, custom,  
1-4 to 1-5

ASICs, custom, 1-4 to 1-5

## B

BIOS

configuration stored in system CMOS,  
3-12 to 3-13

default settings, 4-1

entering BIOS setup, 4-1

setting corrupted CMOS back to  
default, D-3

viewing settings, D-2

board access LEDs

ACC, B-3

DRV, B-3

bulletin board support, E-1

## C

cables, optional, 1-3

capability codes (table), VMEbus, A-3 to A-4

CLK10 signal

accuracy, D-1

definition, D-1

routing, 3-7 to 3-9

SMB CLK10 direction (figure), 3-8

SMB CLK10 polarity (figure), 3-9

SMB CLK10 termination (figure), 3-8

VXIbus CLK10 routing (figure), 3-7

CMOS, setting back to default, 3-12 to 3-13, D-3

COM1 and COM2 connectors and signals,  
C-7 to C-8

common questions about VXIpc 600 Series,  
D-1 to D-3

configuration, 3-1 to 3-13

default settings, 3-1 to 3-5

CPU module attached to

VXI/VMEpc-650 (figure), 3-4

jumper settings (table), 3-5

VMEpc-650 parts locator diagram, 3-3

VXIpc-650 parts locator diagram, 3-2

EEPROM, 3-10 to 3-12

EEPROM operation (figure), 3-11

fixing invalid EEPROM configuration,  
3-11 to 3-12

power-on self configuration status  
(figure), 3-10

PC configuration, 3-12 to 3-13

SCSI termination, 3-12

system CMOS, 3-12 to 3-13

VXI/VMEpc 600 Series, 3-6 to 3-12

EEPROM, 3-10 to 3-12

trigger input termination, 3-9

VXIbus CLK10 routing, 3-7 to 3-9

VXI/VMEbus System Controller,  
3-6 to 3-7

connectors

COM1 and COM2, C-7 to C-8

Ethernet, C-6 to C-7

external SMBs, C-16

GPIO (IEEE-488.2), C-14 to C-15

keyboard and mouse, C-4

list of connectors (table), C-1

parallel port, C-9 to C-10

SCSI, C-12 to C-14

signal characteristics, C-17

Universal Serial Bus, C-11

- VGA, C-5 to C-6
- VXIbus P1 and P2, C-18 to C-22
- CPU module attached to VXI/VMEpc-650 (figure), 3-4
- custom application-specific interface chips, 1-4 to 1-5
- customer communication, *xii*, E-1 to E-2

## D

- default settings, 3-1 to 3-5
  - BIOS setup, 4-1
  - CPU module attached to VXI/VMEpc-650 (figure), 3-4
  - jumpers (table), 3-5
  - parts locator diagrams
    - VMEpc-650, 3-3
    - VXIpc-650, 3-2
- documentation
  - conventions used in manual, *x-xi*
  - how to use documentation set, *xi*
  - organization of manual, *ix*
  - related documentation, *xii*
- DRV LED, B-3

## E

- EEPROM configuration, 3-10 to 3-12
  - EEPROM operation (figure), 3-11
  - fixing invalid EEPROM configuration, 3-11 to 3-12
  - power-on self configuration status (figure), 3-10
- electrical specifications, A-1
- electronic support services, E-1 to E-2
- e-mail support, E-2
- environmental specifications, A-2
- equipment, optional, 1-3

## Ethernet

- connector and signals, C-6 to C-7
- LEDs, B-3 to B-4
  - 100B-T, B-4
  - LNK, B-3
  - RX, B-3
  - TX, B-3
- logic block (table), 2-3
- overview (table), 1-6

## F

### FAIL LED

- description, B-1
- system startup status (table), B-2

- fax and telephone support numbers, E-2

- Fax-on-Demand support, E-2

- front panel. *See also* connectors.

- features, 1-5 to 1-6

- layout and dimensions

- VMEpc-650 (figure), C-3

- VXIpc-650 (figure), C-2

- LED indicators, 1-5 to 1-6, B-1 to B-4

- FTP support, E-1

- functional overview, 2-1 to 2-3

- block diagram, 2-2

- logic blocks (table), 2-3

## G

### GPIB (IEEE 488.2)

- connectors and signals, C-14 to C-15

- logic block (table), 2-3

- overview (table), 1-6

## H

- hardware description, 1-4 to 1-6

- custom application-specific interface chips, 1-4 to 1-5

- front panel features, 1-5 to 1-6

peripherals overview (table), 1-6  
 VME Slot 1 functionality, 1-4  
 VXI Slot 0 functionality, 1-4

## I

IDE controller  
   logic block (table), 2-3  
   overview (table), 1-6  
   using internal IDE drive and external SCSI hard drive, D-3  
 installing VXI/VMEpc 600 Series, 3-13 to 3-14

## J

jumpers  
   CLK10 routing, 3-7 to 3-9  
     SMB CLK10 direction (figure), 3-8  
     SMB CLK10 polarity (figure), 3-9  
     SMB CLK10 termination (figure), 3-8  
     VXIbus CLK10 routing (figure), 3-7  
   CPU module attached to  
     VXI/VMEpc-650 (figure), 3-4  
   default settings (table), 3-5  
   EEPROM configuration, 3-10 to 3-12  
     EEPROM operation (figure), 3-11  
     fixing invalid EEPROM configuration, 3-11 to 3-12  
     power-on self configuration status (figure), 3-10  
   SCSI termination, 3-12  
   system CMOS, 3-12 to 3-13  
   trigger input termination, 3-9  
   VXIbus CLK10 routing, 3-7 to 3-9  
   VXI/VMEbus System Controller, 3-6 to 3-7  
   W20, located on CPU module, 3-4

## K

keyboard connector  
   location and pinout (figure), C-5  
   problems with plugging in keyboards, D-2  
   signals (table), C-5

## L

LabVIEW software, 1-3  
 LabWindows/CVI software, 1-3, 1-4  
 LED indicators  
   board access LEDs  
     ACC, B-3  
     DRV, B-3  
   Ethernet LEDs, B-3 to B-4  
     100B-T, B-4  
     LNK, B-3  
     RX, B-3  
     TX, B-3  
   list of indicators, 1-5 to 1-6  
   questions and answers, D-1  
   VXIbus interface status LEDs, B-1 to B-3  
     FAIL, B-1  
     ONLINE, B-1  
     SYSF, B-1  
     system startup cycle (table), B-2 to B-3  
     TEST, B-1  
 LNK LED, B-3  
 logic blocks (table), 2-3

## M

MANTIS custom ASIC, 1-4 to 1-5  
 manual. *See* documentation.  
 memory requirements, A-1  
 MITE custom ASIC, 1-4  
 MITE EEPROM, 3-10 to 3-12  
 mouse connector, C-4

## N

National Instruments software, 1-3 to 1-4  
NI-488.2M software, 1-3

## O

ONLINE LED  
    description, B-1  
    system startup status, B-2  
optional equipment, 1-3

## P

parallel port  
    connector and signals, C-9 to C-10  
    overview (table), 1-6  
parts locator diagrams  
    VMEpc-650, 3-3  
    VXIpc-650, 3-2  
peripherals  
    overview (table), 1-6  
    PC peripherals logic block (table), 2-3  
physical specifications, A-2

## Q

questions and answers about VXIpc 600  
    Series, D-1 to D-3

## R

RX LED, B-3

## S

SCSI interface  
    connector and signals, C-12 to C-14  
    logic block (table), 2-3  
    overview (table), 1-6  
    questions and answers, D-2 to D-3  
    setting up in BIOS, D-2

serial port  
    connectors and signals, C-7 to C-8  
    overview (table), 1-6  
signals  
    COM1 and COM2 connectors (table), C-8  
    Ethernet connector (table), C-7  
    GPIB (IEEE 488.2) (table), C-15  
    keyboard connector (table), C-5  
    mouse connector (table), C-4  
    P1 and P2 connector signals  
        VMEbus P2 connector signals  
            (table), C-21 to C-22  
        VXIbus P2 connector signals (table),  
            C-20 to C-21  
        VXI/VMEbus P1 connector signals  
            (table), C-19 to C-20  
    parallel port (table), C-10  
    SCSI interface (table), C-12 to C-14  
SMBs  
    characteristics (table), C-17  
    connector signals (table), C-16  
    Universal Serial Bus (table), C-11  
    VGA connector (table), C-5 to C-6  
    VXIbus P1 and P2 (table), C-19 to C-22  
Slot 0 functionality, VXI, 1-4  
Slot 1 functionality, VME, 1-4  
SMB  
    connector location and pinout  
        (figure), C-16  
    signals  
        characteristics (table), C-17  
        connector signals (table), C-16  
    SMB CLK10 direction (figure), 3-8  
    SMB CLK10 polarity (figure), 3-9  
    SMB CLK10 termination (figure), 3-8  
    SMB trigger input termination  
        (figure), 3-9  
software, 1-3 to 1-4

specifications, A-1 to A-4  
 electrical, A-1  
 environmental, A-2  
 physical, A-2  
 requirements, A-1  
 VMEbus capability codes (table),  
 A-3 to A-4

## SYSF LED

description, B-1  
 system startup status (table), B-2

## System Controller

configuration in first slot or alternate slot,  
 D-2

VME functionality, 1-4

VXI functionality, 1-4

VXI/VMEbus System Controller  
 configuration, 3-6 to 3-7

system CMOS, 3-12 to 3-13, D-3

system I/O logic block (table), 2-3

## T

technical support, E-1 to E-2

telephone and fax support numbers, E-2

## TEST LED

description, B-1

system startup status (table), B-2

trigger input termination, 3-9

troubleshooting problems, D-1 to D-3

TX LED, B-3

## U

### Universal Serial Bus (USB)

connectors and signals, C-11

overview (table), 1-6

## V

VGA connector, C-5 to C-6

video interface

logic block (table), 2-3

overview (table), 1-6

VGA connector, C-5 to C-6

VME Slot 1 functionality, 1-4

VMEbus capability codes (table), A-3 to A-4

### VMEpc-650

front panel layout and dimensions  
 (figure), C-3

parts locator diagram, 3-3

### VXIbus

CLK10 routing, 3-7 to 3-9

interface status LEDs, B-1 to B-3

overview (table), 1-6

P1 and P2 connectors and signals,  
 C-18 to C-22

location and pinout (figure), C-18

VMEbus P2 connector signals  
 (table), C-21 to C-22

VXIbus P2 connector signals (table),  
 C-20 to C-21

VXI/VMEbus P1 connector signals  
 (table), C-19 to C-20

System Controller (Slot 0)

functionality, 1-4

### VXIpc-650

front panel layout and dimensions  
 (figure), C-2

parts locator diagram, 3-2

VXI*plug&play* compliance, 1-2, C-1

VXI/VME logic block (table), 2-3

### VXI/VMEpc 600 Series

accessing 32-bit registers, D-1

block diagram, 2-2

configuration. *See* configuration.  
functional description, 2-1 to 2-3  
hardware description, 1-4 to 1-6  
installation, 3-13 to 3-14  
LED indicators, B-1 to B-4  
logic blocks (table), 2-3  
National Instruments software, 1-3 to 1-4  
optional equipment, 1-3  
overview, 1-1 to 1-2  
parts locator diagrams  
    CPU module, 3-4  
    VMEpc-650, 3-3  
    VXIpc-650, 3-2  
specifications, A-1 to A-4  
VME model (figure), 1-2  
VXI model (figure), 1-1